

DRAIN VALVE C09

PN 10, 16; DN 80, 100, 150, 200, 300; T_{MAX}: 200 °C

DRAIN VALVE C09



APPLICATION

- liquids

CONNECTION

- flanged, according to standard EN 1092-1

OPERATION

- handwheel, pneumatic actuator, electric actuator

DESCRIPTION

- rotation rising stem (only with handwheel)
- complies with the requirements of the directive 2014/68/EU
- testing is carried out according to standard EN 12266-1, part 2

BASIC DESIGN OPTIONS

OPERATION BY HANDWHEEL:

- valve for steam
- position indicator

OPERATION BY PNEUMATIC ACTUATOR:

- pneumatic control valve
- air filter and grease nipple
- throttle valve to control closing speed

PRESSURE-TEMPERATURE-RATINGS

Material	PN	Admissible operating pressure PS [bar] at operating temperature TS [°C]					
		-60	-10	50	100	150	200
GX5CrNiMo19-11-2 (1.4408)	10	10	10	10	9,3	8,4	7,8
	16	16	16	16	14,9	13,5	12,4

Warning: Pressure-temperature-ratings specified in the table only apply to the pressure cover of the valve, do not apply to pneumatic actuator.

USED MATERIALS (see the picture below)

1	Body	GX5CrNiMo19-11-2 (1.4408)
2	Disc	X5CrNiMo17-12-2 (1.4401)
3	Bushing	X5CrNiMo17-12-2 (1.4401)
4	Stem	X5CrNiMo17-12-2 (1.4401)
5	Tube	X6CrNiTi 18-10 (1.4541)
6	Valve for steam	GX5CrNiMo19-11-2 (1.4408)
7	Gasket	PTFE

VALVE DIMENSIONS – operation by handwheel

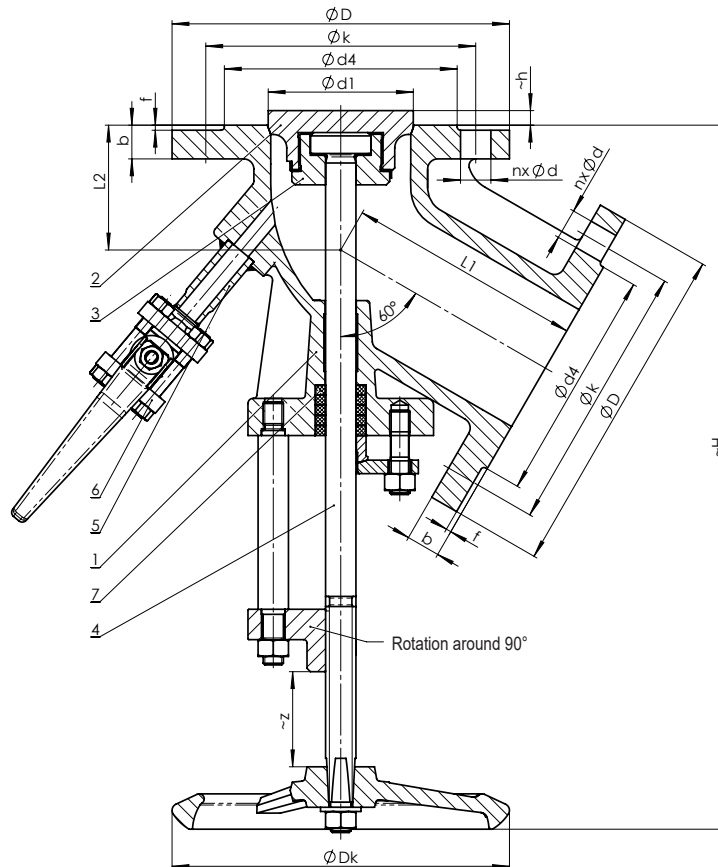

PN	DN	H [mm]	h [mm]	L1 [mm]	L2 [mm]	z [mm]	Dk [mm]	D [mm]	d1 [mm]	d4 [mm]	k [mm]	n x d [mm]	b [mm]	f [mm]	m [kg]
10	80	417	9	140	74	56	200	200	86	138	160	8x18	20	3	20
	100	504	11	160	81	80	250	220	106	158	180	8x18	20	3	26
	150	666	11	212	118	114	315	285	156	212	240	8x22	22	3	43
	200	773	14	243	112	134	315	340	203	268	295	8x22	24	3	88
	300	1080	16	305	162	202	400	445	307	370	400	12x22	26	4	141
16	80	417	9	140	74	56	200	200	86	138	160	8x18	20	3	20
	100	504	11	160	81	80	250	220	106	158	180	8x18	20	3	26
	150	666	11	212	118	114	315	285	156	212	240	8x22	22	3	43
	200	773	14	243	112	134	315	340	203	268	295	12x22	24	3	88
	300	1080	16	307	164	200	400	460	307	378	410	12x26	28	4	147

VALVE DIMENSIONS – operation by pneumatic actuator

Disc down, spring opens

Disc down, spring closes

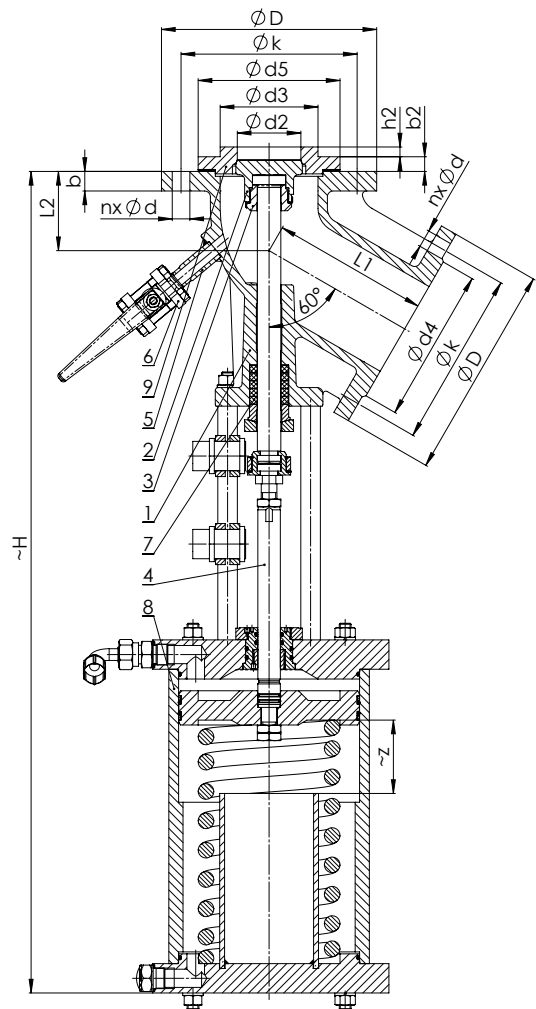
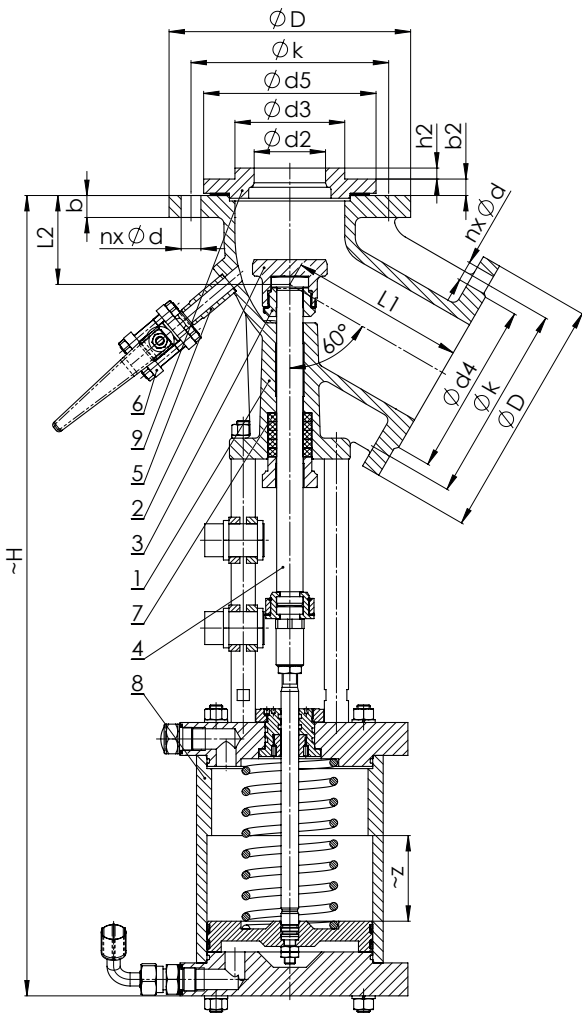

Disc at the top, spring opens

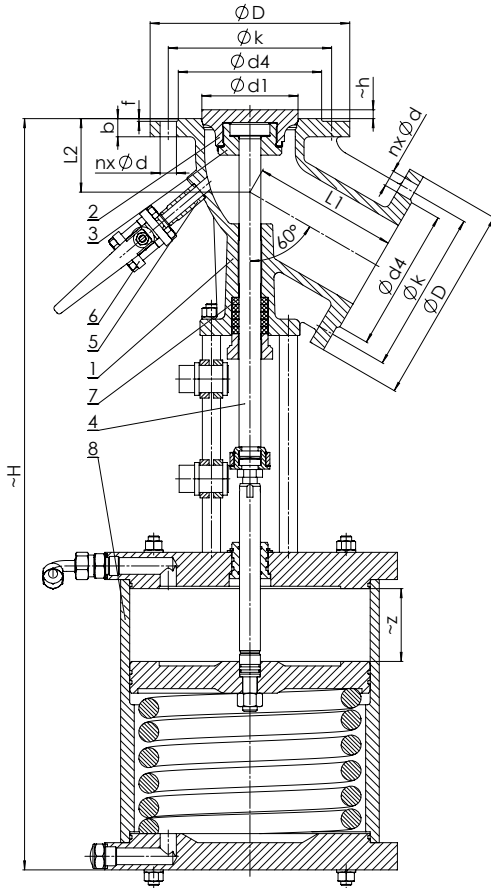

Disc at the top, spring closes

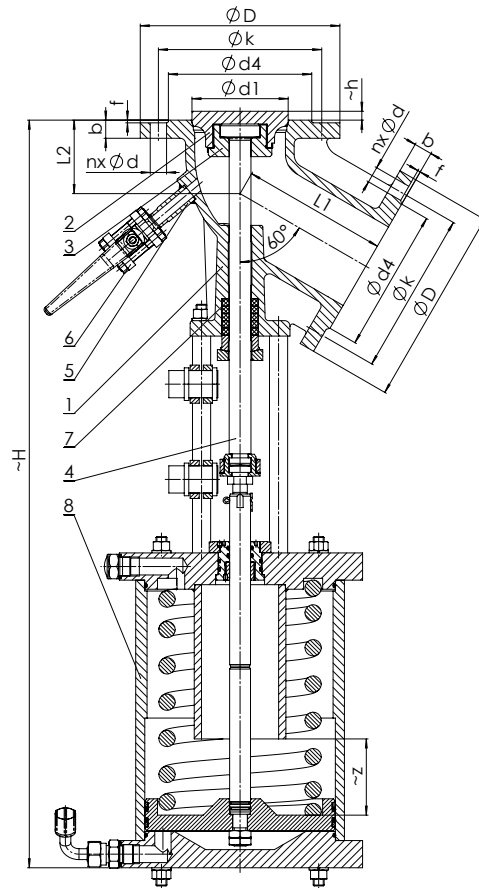

PN	DN	H [mm]	h [mm]	h2 [mm]	L1 [mm]	L2 [mm]	z [mm]	D [mm]	d1 [mm]	d2 [mm]	d3 [mm]	d4 [mm]	d5 [mm]	k [mm]	n x d [mm]	b [mm]	b2 [mm]	f [mm]	m [kg]
10	80	*	9	*	140	74	56	200	86	*	*	138	*	160	8x18	20	*	3	*
	100	824 ¹⁾	11	10	160	81	80	220	106	65	100	158	145	180	8x18	20	15	3	103 ¹⁾
	150	1000 ¹⁾	11	15	212	118	114	285	156	100	150	212	210	240	8x22	22	20	3	145 ¹⁾
	200	1200 ¹⁾	14	20	243	112	134	340	203	153	250	268	270	295	8x22	24	25	3	221 ¹⁾
	300	*	16	*	305	162	202	445	307	*	*	370	*	400	12x22	26	*	4	*

* Values on request

¹⁾ Variable values based on the working pressure of the media

Note: Before ordering, you must specify the working pressure of the medium, in accordance with which the pneumatic actuator will be designed.

VALVE DESCRIPTION CODE

C09 294Z-010-100

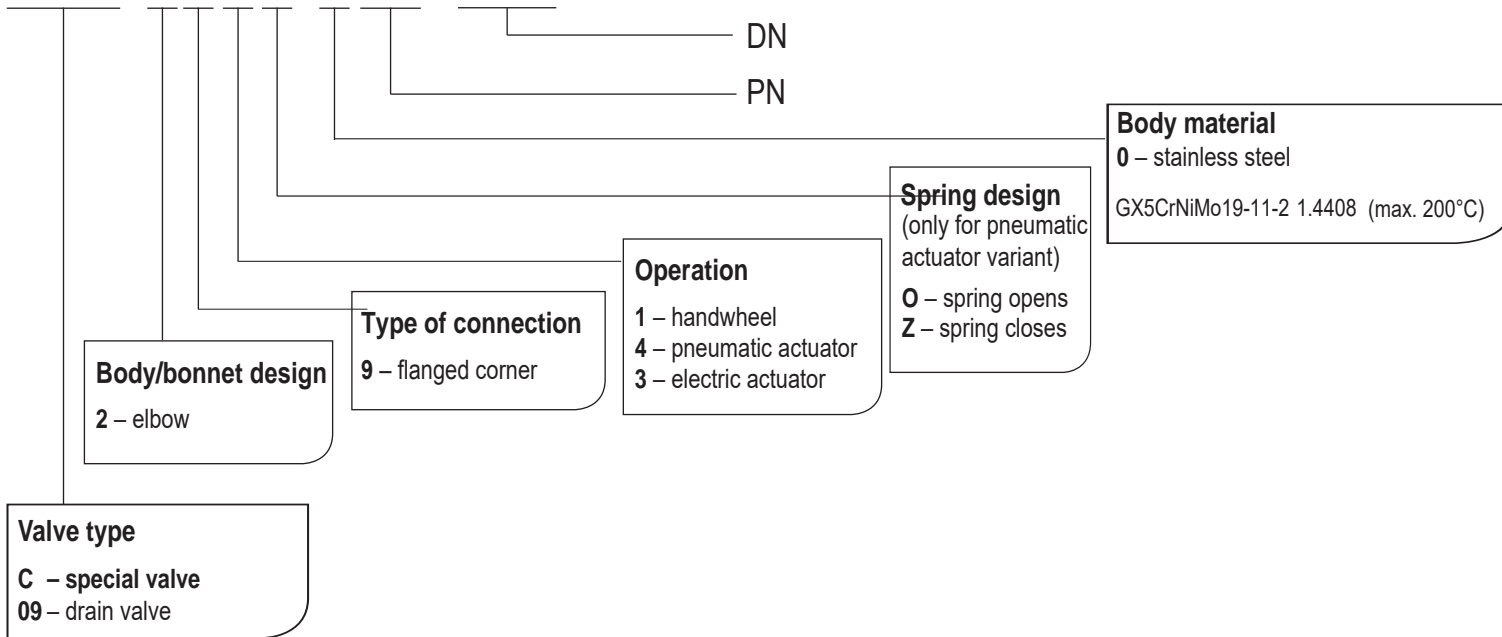

VALVE INSTALLATION

The recommended position of the valve is with the stem and the controls vertically down.

Installation and use the valve following points have to be respected:

- operating conditions must comply with operating parameters of the valve
- proper function of the valve is affected by the presence of impurities in the pipeline and flowing medium, therefore it is necessary keep working environment a pipeline clean, for example with using filters
- medium used must comply with the corrosion resistance of the valve material
- use of mechanically damaged valves during the operation is prohibited

The service life of valves significantly extends regular maintenance and minor repairs carried out by trained personnel.