

# SHUT – OFF GLOBE VALVE WITH BELLOWS C09.1/C09.5

PN 10–40; DN 15–80; T<sub>MAX</sub>: 400 °C



SHUT – OFF GLOBE VALVE WITH BELLOWS C09.1/C09.5

## APPLICATION

- water, steam, gas, oil, petroleum products, non-aggressive and aggressive substances

## CONNECTION

- flanged, weld ends

## OPERATION

- handwheel, gearbox, electric actuator

## DESCRIPTION

- shut-off globe valve C09.1 and shut-off globe valve with control cone and with bellows C09.5
- non-rotating rising stem
- the bellows prevents the medium from penetrating into the gland space
- standard bonnet construction
- design of the body is straight sealing
- sealing surface is welded by hard facing (13Cr) or Stellite 6 (except for stainless steel types)
- complies with the requirements of the directive 2014/68/EU and standard EN 13 709
- testing is carried out according to standard EN 12266-1; part 2

## BASIC DESIGN OPTIONS

- control cone (for rough control) - type C09.5
- according to TRD 201
- TA-Luft

## PRESSURE-TEMPERATURE-RATINGS

Material	PN	Admissible operating pressure PS [bar] at operating temperature TS [°C]										
		-50	-30	-10	50	100	150	200	250	300	350	400
<b>GX5CrNiMo 19-11-2</b> (1.4408) <sup>1)</sup>	10	10	10	10	10	9,3	8,4	7,8	7,3	-	-	-
	16	16	16	16	16	14,9	13,5	12,4	11,7	-	-	-
	25	25	25	25	25	23,3	21,1	19,4	18,3	-	-	-
	40	40	40	40	40	37,3	33,8	31,1	29,3	-	-	-
<b>GX5CrNi19-10</b> (1.4308)	10	10	10	10	9,3	8,4	7,6	6,9	6,4	-	-	-
	16	16	16	16	14,9	13,5	12,1	11	10,3	-	-	-
	25	25	25	25	23,3	21,1	18,9	17,2	16,1	-	-	-
	40	40	40	40	37,3	33,8	30,2	27,6	25,8	-	-	-
<b>G21Mn5</b> (1.1138)	10	-	10	10	10	9,2	8,7	7,9	7,2	6,5	-	-
	16	-	16	16	16	14,8	14	12,8	11,8	10,8	-	-
	25	-	25	25	25	23	21	19,2	18,2	17,2	-	-
	40	-	40	40	40	37	35	32	29,5	27	-	-
<b>GP240GH</b> (1.0619)	10	-	-	10	10	9,3	8,7	7,8	7,1	6,4	6	5,8
	16	-	-	16	16	14,9	13,9	12,4	11,4	10,3	9,6	9,2
	25	-	-	25	25	23,3	21,7	19,4	17,8	16,1	15	14,4
	40	-	-	40	40	37,3	34,7	30,2	28,4	25,8	24	23,1

1) Application for temperatures from -196 °C to +250 °C on request

## USED MATERIALS

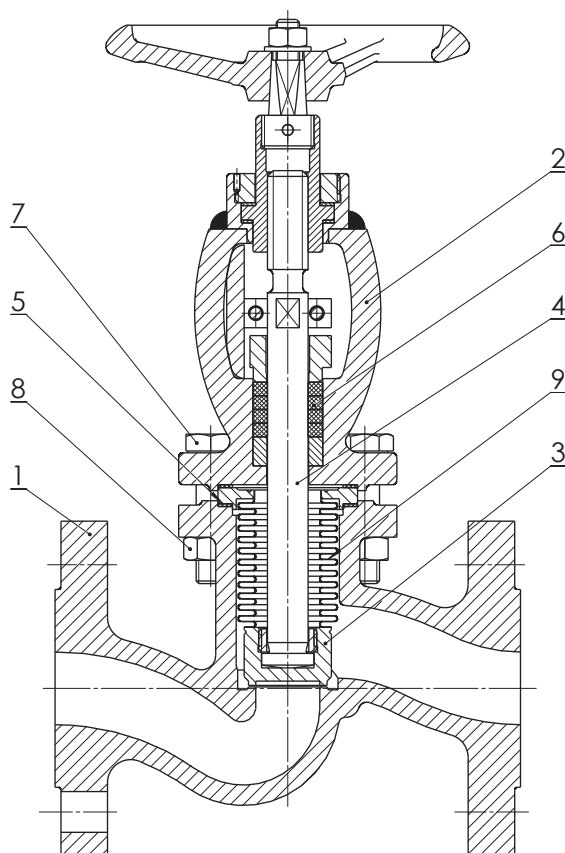

Pos.	Part	Material										
1	Body	GP240GH (1.0619)				G21Mn5 (1.1138)			GX5CrNi19-10 (1.4308)	GX5CrNiMo19-11-2 (1.4408)		
	Hard facing of sealing surface	13Cr	13Cr	18Cr9Ni	18Cr9Ni	Stellite 6	13Cr	18Cr9Ni	Stellite 6	-		
2	Yoke	GP 240 GH (1.0619)				G21Mn5 (1.1138)			GX5CrNi19-10 (1.4308)	GX5CrNiMo19-11-2 (1.4408)		
3	Disc	P250GH (1.0460)				X6CrNiTi18-10 (1.4541)			X6CrNiTi18-10 (1.4541)	X6CrNiMoTi17-12-2 (1.4571)		
	Hard facing of sealing surface	13Cr	Stellite 6	18Cr9Ni	Stellite 6	Stellite 6	-	-	-	-		
4	Stem	X20Cr13 (1.4021)				X20Cr13 (1.4021)			X5CrNi18-10 (1.4301)	X6CrNiMoTi17-12-2 (1.4571)		
5	Gasket	Graphite							Grafit	PTFE	Grafit	PTFE
6	Gland packing	Graphite							Grafit	PTFE	Grafit	PTFE
7	Bolt	A2-70										
8	Nut	A2-70										
9	Bellows	X6CrNiTi18-10 (1.4541)										

**VALVE DIMENSIONS**

**1. Flanged**

Face-to-face dimensions: EN 558 – line 1  
 Flanges: EN 1092-1

**2. Weld ends**

Face-to-face dimensions: EN 12982 – line 1  
 Dimensions of welding ends: DIN 3239 – part 1  
 Groove form: DIN 2559 – sheet 1 – form 22

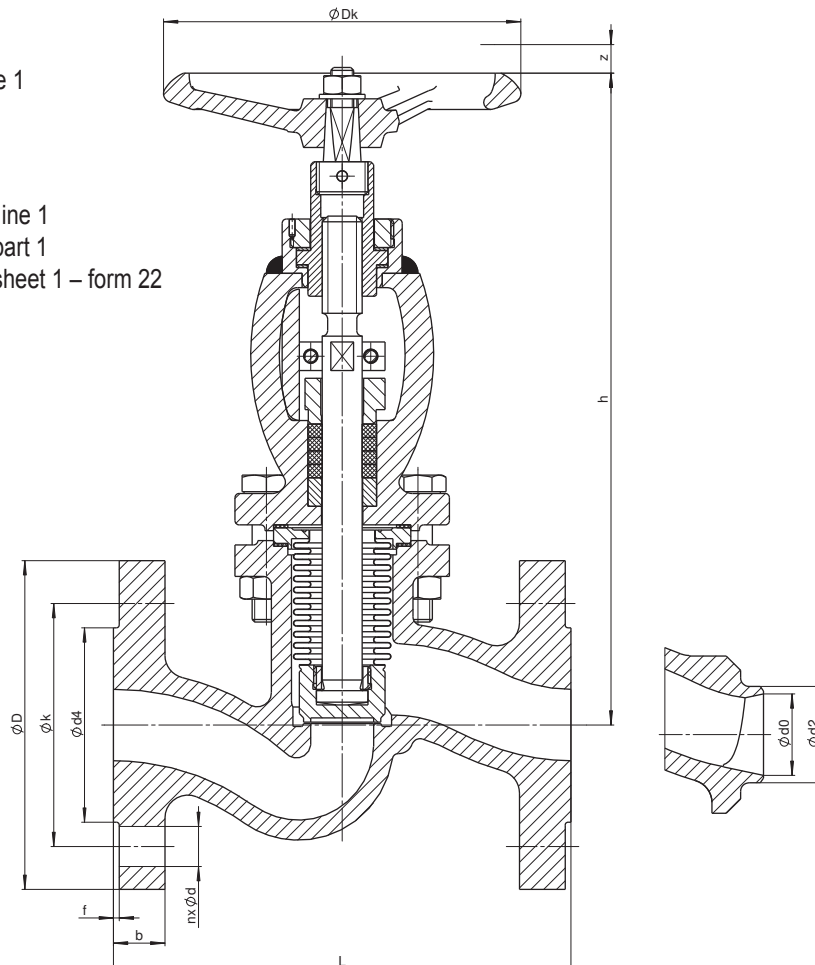

Nominal pressure	Nominal size	Face-to-face	Centre-to-top-height	Stroke	Handwheel	Flanged						Weld ends				
						PN	DN	L [mm]	h [mm]	z [mm]	Dk [mm]	n	d [mm]	k [mm]	D [mm]	b [mm]
10, 16, 25, 40	15	130	186	4	125	4	14	65	95	16	45×2	3,5	22	17	2,5	21,3×2,0
	20	150	225	6	125	4	14	75	105	18	58×2	5,5	28	22	4,0	26,9×2,3
	25	160	230	8	125	4	14	85	115	18	68×2	6,0	34	28,5	4,5	33,7×2,6
	32	180	250	9	160	4	18	100	140	18	78×2	9,0	43	37	6,0	42,4×2,6
	40	200	275	11	200	4	18	110	150	18	88×3	11,5	49	43	8,5	48,3×2,6
	50	230	290	13	200	4	18	125	165	20	102×3	16,5	61	54	12,0	60,3×3,2
25, 40	65	290	425	16	250	8	18	145	185	22	122×3	36,5	77	69	30,5	76,1×3,6
	80	310	425	16	250	8	18	160	200	24	138×3	41,0	90	81	34,0	88,9×4,0

## DESIGN VARIANTS

**ADJUSTMENT FOR ACTUATOR  
– FORM C ACCORDING TO EN ISO 5210**

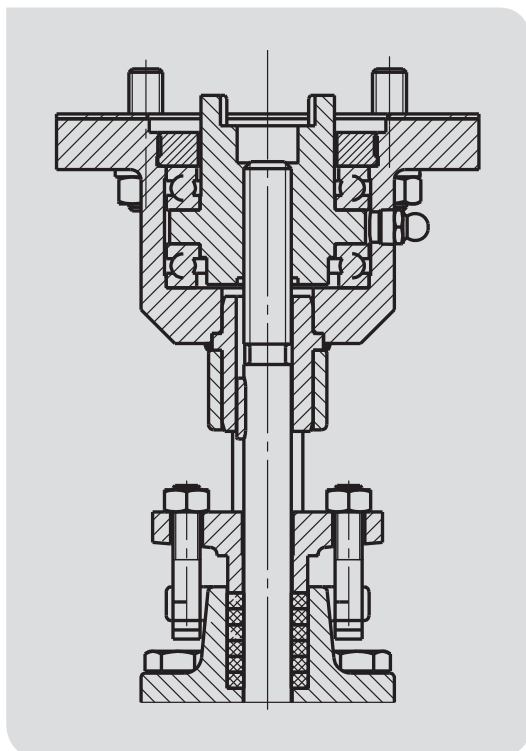

**CONTROL CONE**

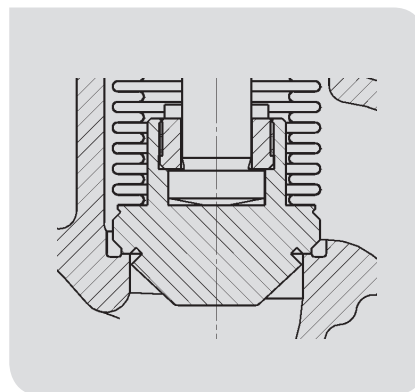

## VALVE DESCRIPTION CODE

# C09.1 111–540–80

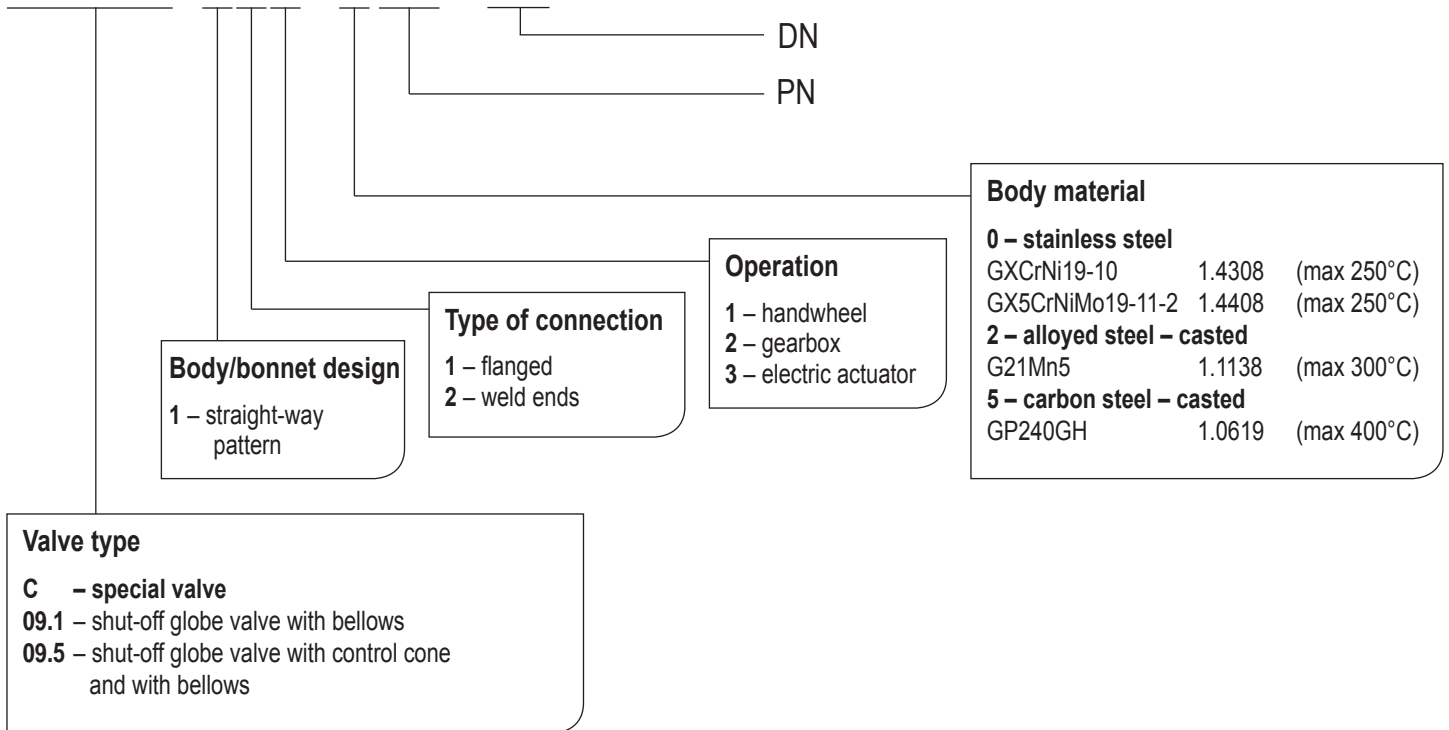

## VALVE INSTALLATION

Valve can be installed in any position. Medium must flow in accordance with the direction indicated on the body. It is necessary to consider the following points during assembly and operation:

- operating conditions must comply with operating parameters of the valve
- proper function of the valve is affected by the presence of impurities in the pipeline and flowing medium, therefore it is necessary keep working environment a pipeline clean
- medium used must comply with the corrosion resistance of the valve material
- use of mechanically damaged valves during the operation is prohibited

**The service life of valves significantly extends regular maintenance and minor repairs carried out by trained personnel.**