

MUD-DISCHARGING VALVE B10.3

PN 63–500; DN 10–50; T_{MAX}: 580 °C



MUD-DISCHARGING VALVE B10.3

APPLICATION

- turbid boiler water (boiler mud and sludge)

CONNECTION

- weld ends, flanged

OPERATION

- handwheel

DESCRIPTION

- body without cover
- rotating rising stem
- two handwheels, large wheel for opening and closing, small for removal of dirt from the seat
- sealing surfaces are welded by hard steel or stellite for high temperature
- welded or flanged design
- straight-way pattern
- complies with the requirements of the directive 2014/68/EU, EN 13 709
- testing is carried out according to EN 12266-1

BASIC DESIGN OPTIONS

- graphite gasket
- other tests according to customer's request
- delivery according to TRD 201 on request

PRESSURE-TEMPERATURE-RATINGS

Material	PN	Admissible operating pressure PS [bar] at operating temperature TS [°C]																			
		-10	50	100	150	200	250	300	350	400	450	500	510	520	530	540	550	560	570	580	
P250GH (C22.8) (1.0460)	63	63	63	63	63	63	44.8	40.6	37.8	36.4	21	-	-	-	-	-	-	-	-	-	
	100	100	100	100	100	100	71.1	64.4	60	57.8	33	-	-	-	-	-	-	-	-	-	
	160	160	160	160	160	160	110	94.1	88.3	78.5	45	-	-	-	-	-	-	-	-	-	
	250	250	250	250	250	250	172	147	137	123	70	-	-	-	-	-	-	-	-	-	
	320	320	320	320	320	320	320	273	233	182	103	-	-	-	-	-	-	-	-	-	
	400	400	400	400	400	400	400	342	290	227	129	-	-	-	-	-	-	-	-	-	-
	500	500	500	500	500	500	490	427	364	284	162	-	-	-	-	-	-	-	-	-	-
11CrMo9-10 (1.7383)	63	63	63	63	63	63	63	61.8	59.8	56.9	54.9	46.1	38.7	31.4	27.4	23.5	20	17.3	14.8	12.8	
	100	100	100	100	100	100	100	98.1	93.2	89.2	85.3	72.6	60.3	48.1	42	35.9	30.7	26.4	22.7	19.6	
	160	160	160	160	160	160	160	152	150	143	136	116	96.5	77.5	68.6	59.8	51	44	37.8	32.5	
	250	250	250	250	250	250	250	237	233	223	213	180	151	122	107	93.2	79.4	68.4	58.9	50.7	
	320	320	320	320	320	320	320	314	298	286	273	232	193	155	137	119	102	87.9	75.6	65.1	
	400	400	400	400	400	400	400	392	373	357	341	289	241	194	171	148	127	109	94.2	81	
	500	500	500	500	500	500	500	500	500	500	500	426	375	325	285	246	215	188	161	143	

Material	PN	Admissible operating pressure PS [bar] at operating temperature TS [°C]																	
		-10	50	100	150	200	250	300	350	400	450	500	510	520	530	540	550	560	570
13CrMo4-5 (1.7335)	63	63	63	63	63	63	61.6	57.4	53.2	50.4	47.6	38.4	32.5	26.3	21.8	17.6	13.7	-	-
	100	100	100	100	100	100	97.8	91.1	84.4	80	75.6	60.9	51.6	41.8	34.7	28	21.8	-	-
	160	160	160	160	160	160	157	152	150	143	136	116	98.1	77.5	60.8	45.1	34.3	-	-
	250	250	250	250	250	250	245	237	233	223	213	180	151	122	95.1	71.6	53	-	-
	320	320	320	320	320	320	320	314	298	286	273	232	196	155	122	91.2	67.7	-	-
	400	400	400	400	400	400	400	392	373	357	341	289	245	194	152	114	85.3	-	-
	500	500	500	500	500	500	500	500	500	500	489	433	363	287	234	189	148	-	-

Material	PN	Admissible operating pressure PS [bar] at operating temperature TS [°C]																	
		-10	50	100	150	200	250	300	350	400	450	500	510	520	530	540	550	560	570
13CrMo4-5 (1.7335)	63	63	63	63	63	63	61.6	57.4	53.2	50.4	47.6	38.4	32.5	26.3	21.8	17.6	13.7	-	-
	100	100	100	100	100	100	97.8	91.1	84.4	80	75.6	60.9	51.6	41.8	34.7	28	21.8	-	-
	160	160	160	160	160	160	157	152	150	143	136	116	98.1	77.5	60.8	45.1	34.3	-	-
	250	250	250	250	250	250	245	237	233	223	213	180	151	122	95.1	71.6	53	-	-
	320	320	320	320	320	320	320	314	298	286	273	232	196	155	122	91.2	67.7	-	-
	400	400	400	400	400	400	400	392	373	357	341	289	245	194	152	114	85.3	-	-
	500	500	500	500	500	500	500	500	500	500	489	433	363	287	234	189	148	-	-

USED MATERIALS

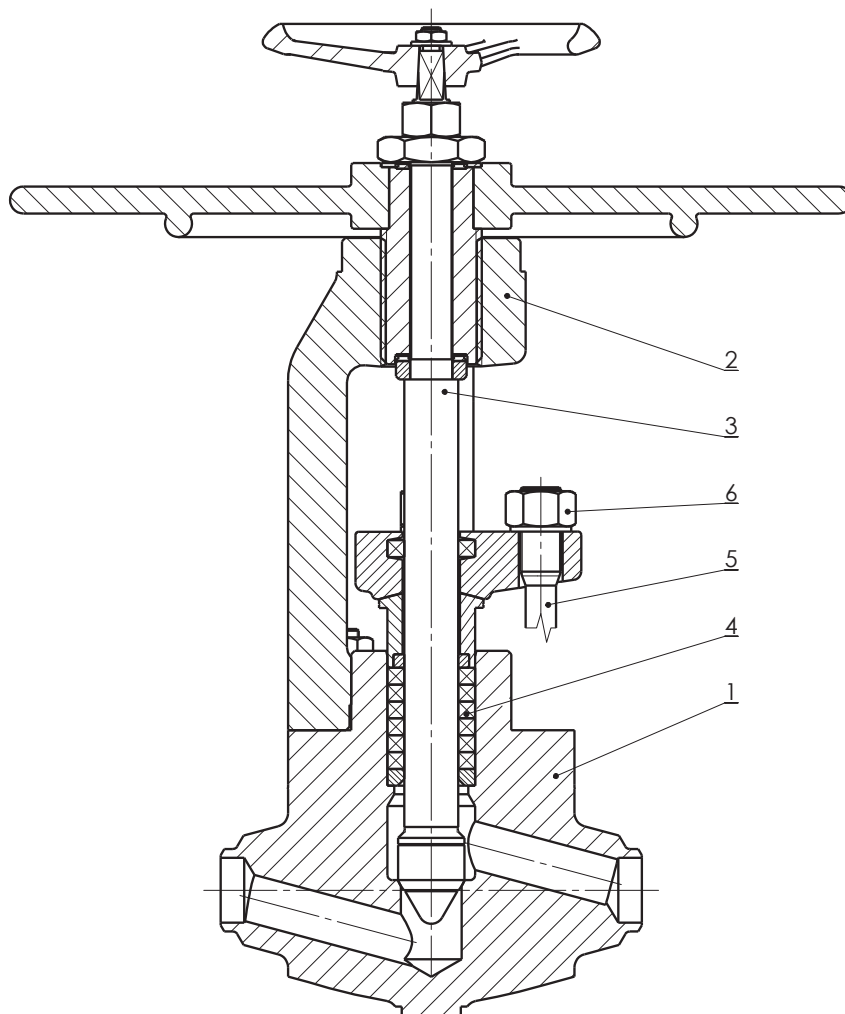

Pos.	Part	Material			
1	Body	P250GH (C 22.8) (1.0460)	11CrMo9-10 (1.7383)	13CrMo4-5 (1.7335)	X6CrNiMoTi17-12-2 (1.4571)
	Hard facing of sealing surface	13Cr	Stellite 6		
2	Bonnet	11CrMo9-10 (1.7383)	11CrMo9-10 (1.7383)	13CrMo4-5 (1.7335)	X6CrNiMoTi17-12-2 (1.4571)
3	Stem with disk	X20Cr13 (1.4021)	X20CrMoV11-1 (1.4922)		X6CrNiMoTi17-12-2 (1.4571)
	Hard facing of sealing surface	Hardening	Stellite 6		
4	Gasket	Graphite			
5	Stud	21CrMov5-7 (1.7709)		X22CrMoV12-1 (1.4923)	
6	Nut	25CrMo4 (1.7218)		X22CrMoV12-1 (1.4923)	

VALVE DIMENSIONS

1. Weld ends

Face-to-face dimensions: according to the manufacturer's standard
 Weld ends: DIN 3239 – part 1
 Groove form: DIN 2559 – sheet 1 – form 22

2. Flanged

Face-to-face dimensions: according to the manufacturer's standard
 Flanges: EN 1092-1 (DIN 2501/1972)

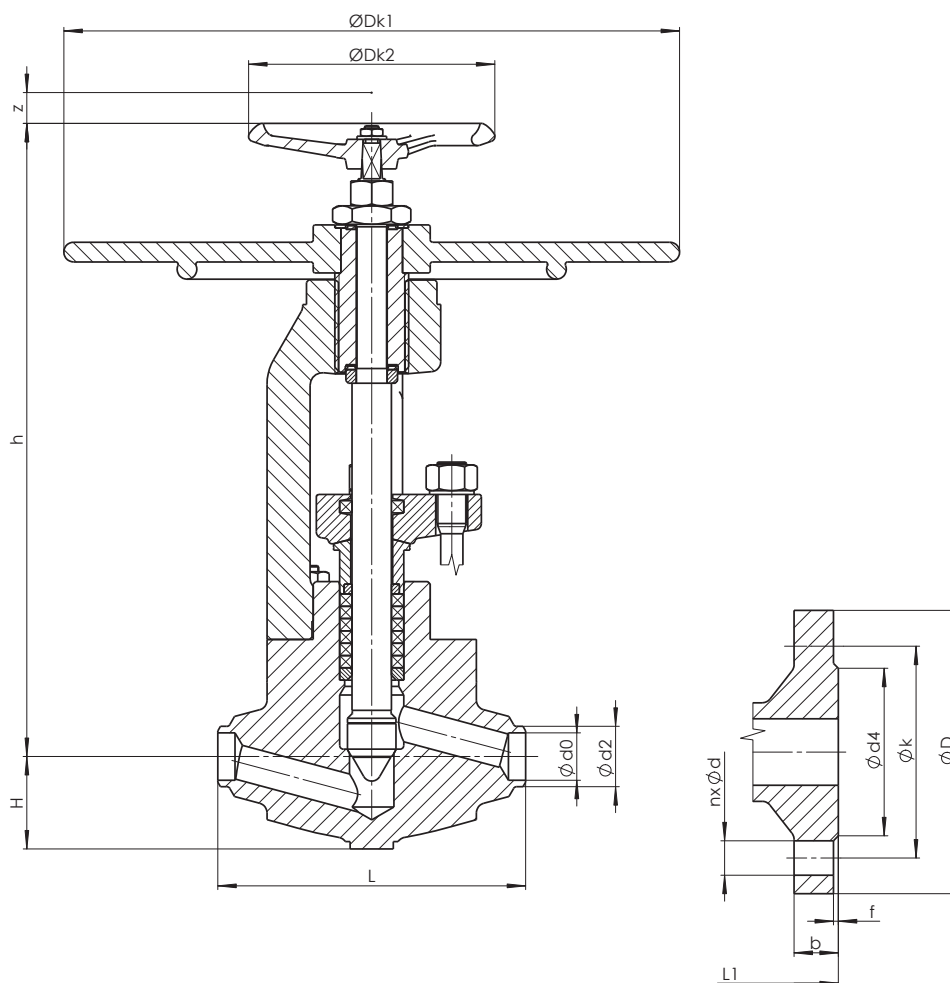

WELDING ENDS

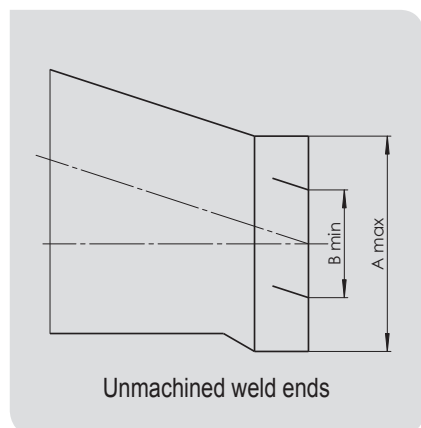

WELDING DESIGN

Nominal pressure	Nominal size	Face-to-face	Centre-to-top	Centre-to-top	Stroke	Handwheel	Handwheel	Weld ends		Pipe dimensions	Dimension of unmachined weld ends		Approximate weight
PN	DN	L	h	H	z	ØDk1	ØDk2	d2	d0		Amax	Bmin	m [kg]
63	10	150	300	30	-	160	250	18	13,0	17,2x2,0	9	32	-
	15	150	300	30	-	160	250	22	17,0	21,3x2,0	14	32	-
	20	160	350	45	-	160	250	28	22,0	26,9x2,3	19	50	-
	25	160	350	45	-	160	250	34	28,5	33,7x2,6	22	50	-
	40	250	515	75	30	300	500	49	43,0	48,3x2,6	32	88	65
	50	250	515	75	30	300	500	61	54,0	60,3x3,2	40	88	65
100	10	150	300	30	-	160	250	18	13,0	17,2x2,0	9	32	-
	15	150	300	30	-	160	250	22	17,0	21,3x2,0	14	32	-
	20	160	350	45	-	160	250	28	22,0	26,9x2,3	19	50	-
	25	160	350	45	-	160	250	34	28,5	33,7x2,6	22	50	-
	40	250	515	75	30	300	500	49	43,0	48,3x2,6	32	88	65
	50	250	515	75	30	300	500	61	54,0	60,3x3,2	40	88	65
160	10	150	300	30	-	160	250	18	13,0	17,2x2,0	9	32	-
	15	150	300	30	-	160	250	22	17,0	21,3x2,0	14	32	-
	20	160	350	45	-	160	250	28	22,0	26,9x2,3	19	50	-
	25	160	350	45	-	160	250	34	27,5	33,7x3,2	22	50	-
	40	250	515	75	30	300	500	49	41,0	48,3x3,6	32	88	65
	50	250	515	75	30	300	500	61	52,5	60,3x4,0	40	88	65
250	10	150	300	30	-	160	250	18	12,0	17,2x2,6	9	32	-
	15	150	300	30	-	160	250	22	16,0	21,3x2,6	14	32	-
	20	160	350	45	-	160	250	28	20,0	26,9x3,6	19	50	-
	25	160	350	45	-	160	250	35	26,5	33,7x3,6	22	50	-
	40	250	515	75	30	300	500	49	38,5	48,3x5,0	32	88	65
	50	250	515	75	30	300	500	61	45,0	60,3x8,0	40	88	65
320	10	150	-	-	-	-	-	18	12,0	17,2x2,6	9	32	-
	15	150	-	-	-	-	-	22	15,0	21,3x3,2	14	32	-
	20	160	-	-	-	-	-	28	19,0	26,9x4,0	19	50	-
	25	160	-	-	-	-	-	35	24,0	33,7x5,0	22	50	-
	40	250	515	75	30	300	500	49	36,0	48,3x6,3	32	88	65
	50	250	515	75	30	300	500	77	59,5	76,1x8,8	40	88	65
400	10	150	-	-	-	-	-	18	10	17,2x3,6	9	32	-
	15	150	-	-	-	-	-	28	17	26,9x5,0	14	32	-
	20	160	-	-	-	-	-	34	19,5	32,0x6,3	19	50	-
	25	160	-	-	-	-	-	44	28	42,4x8,0	22	50	-
	40	250	515	75	30	300	500	61	39	60,3x11,0	32	88	65
	50	250	515	75	30	300	500	76	49	76,1x14,2	40	88	65
500	10	150	-	-	-	-	-	22	11,5	21,3x5,0	9	32	-
	15	150	-	-	-	-	-	33	16,5	32,0x8,0	14	32	-
	20	160	-	-	-	-	-	38	20,5	38,0x8,8	19	50	-
	25	160	-	-	-	-	-	48	23,5	48,3x12,5	22	50	-
	40	250	515	75	30	300	500	76	42	76,1x17,5	32	88	65
	50	250	515	75	30	300	500	*)	*)	*)	40	88	65

Missing parameters on request *)

FLANGE DESIGN

Nominal pressure	Nominal size	Face-to-face	Number of holes	Hole	Pitch circle	Flange diameter	Flange thickness	Sealing bar
PN	DN	L _f	n	ød	øk	øD	b	ød _{4xf}
63	10	260	4	14	70	100	20	40x2
	15	260	4	14	75	105	20	45x2
	20	-	-	-	-	-	-	-
	25	300	4	18	100	140	24	68x2
	32	-	-	-	-	-	-	-
	40	400	4	22	125	170	26	88x3
	50	400	4	22	135	180	26	102x3
100	10	260	4	14	70	100	20	40x2
	15	260	4	14	75	105	20	45x2
	20	-	-	-	-	-	-	-
	25	300	4	18	100	140	24	68x2
	32	-	-	-	-	-	-	-
	40	400	4	22	125	170	26	88x3
	50	400	4	26	135	180	28	102x3
160	10	260	4	14	70	100	20	40x2
	15	260	4	14	75	105	20	45x2
	20	-	-	-	-	-	-	-
	25	300	4	18	100	140	24	68x2
	32	-	-	-	-	-	-	-
	40	400	4	22	125	170	28	88x3
	50	400	4	26	145	195	30	102x3
250	10	260	4	18	85	125	24	40x2
	15	260	4	18	90	130	26	45x2
	20	-	-	-	-	-	-	-
	25	300	4	22	105	150	28	68x2
	32	-	-	-	-	-	-	-
	40	400	4	26	135	185	34	88x3
	50	400	8	26	150	200	38	102x3
320	10	260	4	18	85	125	24	40x2
	15	260	4	18	90	130	26	45x2
	20	-	-	-	-	-	-	-
	25	300	4	22	115	160	34	68x2
	32	-	-	-	-	-	-	-
	40	400	4	26	145	195	38	88x3
	50	400	8	26	160	210	42	102x3
400	10	260	4	18	85	125	28	40x2
	15	260	4	22	100	145	30	45x2
	20	-	-	-	-	-	-	-
	25	300	4	26	130	180	38	68x2
	32	-	-	-	-	-	-	-
	40	400	4	30	165	220	48	88x3
	50	400	8	30	180	235	52	102x3

DN20 and DN32 - on customer request

VALVE DESCRIPTION CODE

B10.3 111-3320-25

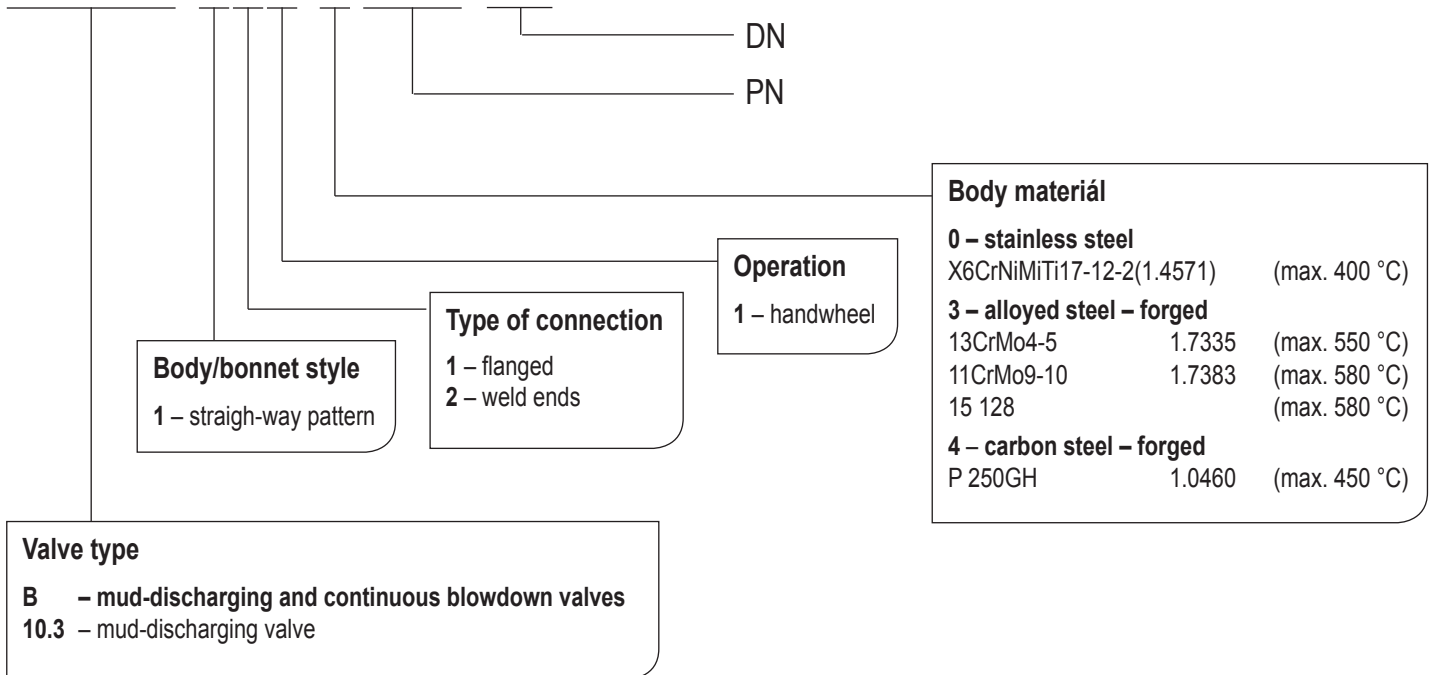

VALVE INSTALLATION

The valve is mounted in straight pipe sections with an uninterrupted flow of working fluid. Recommended valve position - stem and controls perpendicular upwards, mounting with hanging spindle is not permitted. Medium must flow in accordance with the direction indicated by an arrow on the valve body. Mud-discharging valves are not intended as shut-off valves, for a safe shut-off the shut-off valve of the same DN is inserted before or after these valves.

It is necessary to consider the following points during assembly and operation:

- operating conditions must comply with operating parameters of the valve
- the medium used must be comply with the corrosion resistance of the valve material
- use of mechanically damaged valves during the operation is prohibited

The service life of valves significantly extends regular maintenance and minor repairs carried out by trained personnel.