

HIGH-PRESSURE SHUT-OFF GLOBE VALVE V46.3/V40.3

PN 63–250 ONLY FOR DN 65; PN 320–630; DN 10–50; T_{MAX}: 600 °C

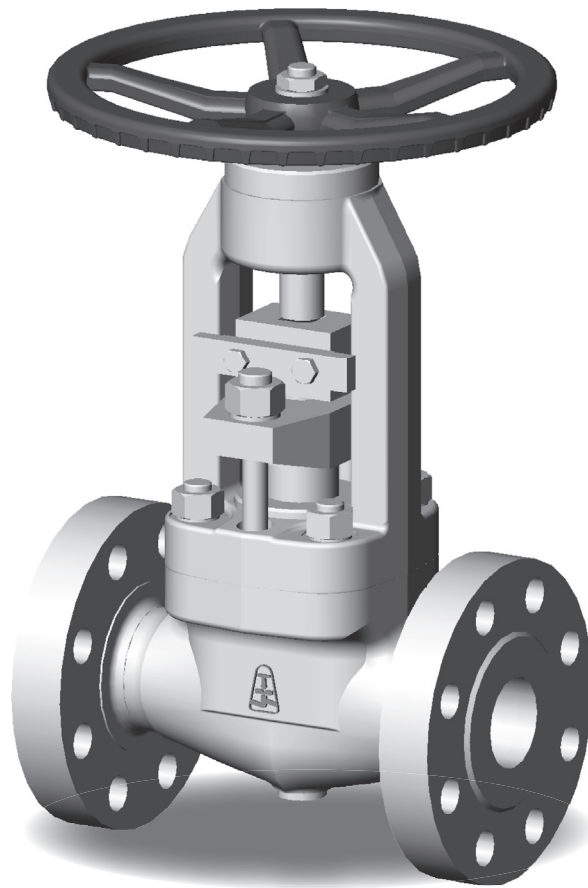

HIGH-PRESSURE SHUT-OFF GLOBE VALVE V46.3/V40.3

APPLICATION

- water, steam, gas, oil, petroleum products, non-aggressive and aggressive substances

CONNECTION

- flanged, weld ends, threaded ends, combination

OPERATION

- handwheel, electric actuator, gearbox, attachment for pneumatic or hydraulic actuator, remote control

DESCRIPTION

- high-pressure shut-off valve V46.3 and high-pressure shut-off valve with control cone V40.3
- forged material
- non-rotating rising stem
- one-piece body without cover
- stem gland packing in body
- sealing surface is welded by hard facing (13Cr) or Stellite 6
- position indicator
- complies with the requirements of the directive 2014/68/EU and standard EN 13709
- testing is carried out according to standard EN 12266-1, part 2

BASIC DESIGN OPTIONS

- control cone (for rough control) – type V40.3
- according to TRD 201
- limit switches
- gland with scraper ring

PRESSURE-TEMPERATURE-RATINGS

Material	PN	Admissible operating pressure PS [bar] at operating temperature TS [°C]																		
		-10	50	100	150	200	250	300	350	400	450	500	510	520	530	540	550	560	570	580
P250GH (1.0460)	63	63	63	63	63	63	63	44.8	40.6	37.8	36.4	21	-	-	-	-	-	-	-	-
	100	100	100	100	100	100	100	71.1	64.4	60	57.8	33	-	-	-	-	-	-	-	-
	160	160	160	160	160	160	160	110	94.1	88.3	78.5	45	-	-	-	-	-	-	-	-
	250	250	250	250	250	250	250	172	147	137	123	70	-	-	-	-	-	-	-	-
	320	320	320	320	320	320	320	320	273	233	182	103	-	-	-	-	-	-	-	-
	400	400	400	400	400	400	400	400	342	290	227	129	-	-	-	-	-	-	-	-
	500	500	500	500	500	500	500	490	427	364	284	162	-	-	-	-	-	-	-	-
16Mo3 (1.5415)	63	63	63	63	63	60,2	56	47,6	44,8	42	40,6	28,3	21,5	17	13,6	-	-	-	-	-
	100	100	100	100	100	95,6	88,9	75,6	71,1	66,7	64,4	44,9	34,1	26,9	21,6	-	-	-	-	-
	160	160	160	160	160	157	147	136	123	116	110	79,9	60,7	47,9	38,4	-	-	-	-	-
	250	250	250	250	250	245	229	213	191	181	171	124	94,2	74,4	59,5	-	-	-	-	-
	320	320	320	320	320	320	320	320	318	298	288	179	136	107	86	-	-	-	-	-
	400	400	400	400	400	400	400	400	398	373	360	224	170	134	108	-	-	-	-	-
	500	500	500	500	500	500	500	500	484	422	398	361	321	184	145	116	-	-	-	-
13CrMo4-5 (1.7335)	63	63	63	63	63	63	61.6	57.4	53.2	50.4	47.6	38.4	32.5	26.3	21.8	17.6	13.7	-	-	-
	100	100	100	100	100	100	97.8	91.1	84.4	80	75.6	60.9	51.6	41.8	34.7	28	21.8	-	-	-
	160	160	160	160	160	160	157	152	150	143	136	116	98.1	77.5	60.8	45.1	34.3	-	-	-
	250	250	250	250	250	250	245	237	233	223	213	180	151	122	95.1	71.6	53	-	-	-
	320	320	320	320	320	320	320	314	298	286	273	232	196	155	122	91.2	67.7	-	-	-
	400	400	400	400	400	400	400	392	373	357	341	289	245	194	152	114	85.3	-	-	-
	500	500	500	500	500	500	500	500	500	500	500	489	433	363	287	234	189	148	-	-
11CrMo9-10 (1.7383)	63	63	63	63	63	63	63	61.8	59.8	56.9	54.9	46.1	38,7	31,4	27,4	23,5	20	17,3	14,8	12,8
	100	100	100	100	100	100	100	98.1	93.2	89.2	85.3	72.6	60,3	48.1	42	35.9	30.7	26.4	22.7	19.6
	160	160	160	160	160	160	160	152	150	143	136	116	96,7	77.5	68,6	59.8	51	44	37.8	32.5
	250	250	250	250	250	250	250	237	233	223	213	180	151	122	107	93.2	79.4	68.4	58.9	50.7
	320	320	320	320	320	320	320	314	298	286	273	232	193	155	137	119	102	87.9	75.6	65.1
	400	400	400	400	400	400	400	392	373	357	341	289	241	194	171	148	127	109	94.2	81
	500	500	500	500	500	500	500	500	500	500	500	426	375	325	285	246	215	188	161	143
	630	630	630	630	630	630	630	630	630	630	630	490	426	369	320	276	235	202	174	149

Material	PN	Admissible operating pressure PS [bar] at operating temperature TS [°C]																		
		-196 ¹⁾	-10	50	100	150	200	250	300	350	400	450	500	510	520	530	540	550	560	570
X6CrNiMoTi 17-12-2 (1.4571)	63	63	63	63	61.6	57.4	53.8	51.2	49	47.3	45.9	-	-	-	-	-	-	-	-	-
	100	100	100	100	97.8	91.1	85.3	81.3	77.8	75.1	72.9	-	-	-	-	-	-	-	-	-
	160	160	160	160	146	140	131	125	119	115	112	-	-	-	-	-	-	-	-	-
	250	250	250	250	229	218	204	195	186	180	174	-	-	-	-	-	-	-	-	-
	320	320	320	320	293	279	261	249	238	230	223	-	-	-	-	-	-	-	-	-
	400	400	400	400	366	349	327	311	298	288	279	-	-	-	-	-	-	-	-	-

1) Application for temperatures - 196 °C to + 400 °C on request

Material	PN	Admissible operating pressure PS [bar] at operating temperature TS [°C]																			
		-10	200	250	300	350	400	450	480	490	500	510	520	530	540	550	560	570	580	590	600
X10CrMo VNb9-1 (P91) (1.4903) ²⁾	63	63	63	63	63	63	63	63	63	63	63	63	63	63	63	63	63	63	63	63	
	100	100	100	100	100	100	100	100	100	100	100	100	100	100	100	100	100	100	100	100	
	160	160	160	160	160	160	160	160	160	160	160	160	160	160	160	160	160	160	160	160	160
	250	250	250	250	250	250	250	250	250	250	250	250	250	250	250	250	250	250	250	250	250
	320	320	320	320	320	320	320	320	320	320	320	320	320	320	320	320	320	320	320	320	320
	400	400	400	400	400	400	400	400	400	400	400	400	400	400	400	400	400	400	400	400	400
	500	500	500	500	500	500	500	500	500	500	500	500	500	500	500	500	500	500	500	500	500
	630	630	630	630	630	630	630	630	630	630	630	630	630	630	630	630	630	630	630	630	630

2) Application for temperatures up to + 650 °C on request

USED MATERIALS

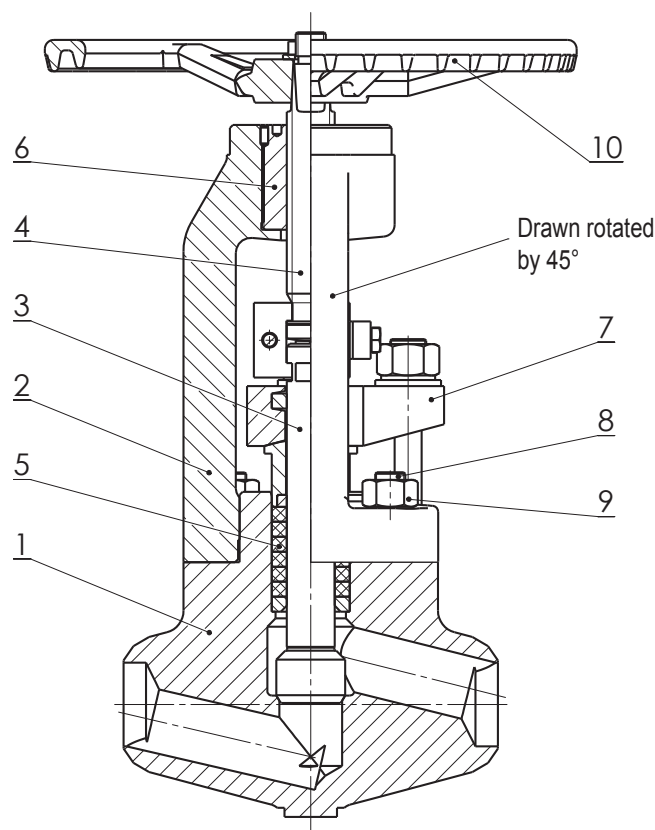

Pos.	Part	Material					
1	Body	P250GH (1.0460) (11 416)	16Mo3 (1.5415)	13CrMo4-5 (1.7335)	11CrMo9-10 (1.7383)	X6CrNiMoTi17-12-2 (1.4571)	X10CrMoVNb9-1, (P91), (1.4903)
	Hard facing of sealing surface	13Cr	Stellite 6				
2	Yoke	11CrMo9-10 (1.0460, 1.7380, 1.7383)	11CrMo9-10 (1.7335, 1.7383)	11CrMo9-10 (1.7335, 1.7383)	11CrMo9-10 (1.7383)	X6CrNiMoTi17-12-2 (1.4571)	11CrMo9-10 (1.7383)
3	Disc	X20Cr13 (1.4021)	X22CrMoV12-1 (1.4923)	X22CrMoV12-1 (1.4923)	X22CrMoV12-1 (1.4923)	X6CrNiMoTi17-12-2 (1.4571)	X20CrMoV11-1 (1.4922)
	Hard facing of sealing surface	Hardened	Stellite 6				
4	Stem	X20Cr13 (1.4021)	X22CrMoV12-1 (1.4923)	X22CrMoV12-1 (1.4923)	X22CrMoV12-1 (1.4923)	X39CrMo17-1 (1.4122)	X20CrMoV11-1 (1.4922)
5	Packing	Graphite					
6	Stem nut	11 110 (10S20) (1.0721)					
7	Flange	P250GH (C 22.8) (1.0425, 1.0460)	11CrMo9-10 (1.7383)	16Mo 3 (1.5415)	13CrMo4-5 (1.7335)	11CrMo9-10 (1.7383)	11CrMo9-10 (1.7383)
8	Bolt	21CrMoV5-7 (1.7709)	21CrMoV5-7 (1.7709)	21CrMoV5-7 (1.7709)	21CrMoV5-7 (1.7709)	X22CrMoV12-1 (1.4923)	X22CrMoV12-1 (1.4923)
9	Nut	25CrMo4 (1.7218)	25CrMo4 (1.7218)	25CrMo4 (1.7218)	25CrMo4 (1.7218)	X22CrMoV12-1 (1.4923)	X22CrMoV12-1 (1.4923)
10	Handwheel	EN-GJL-300 (GG – 30)					

VALVE DIMENSIONS

1. Flanged

Face-to-face dimensions: according to the manufacturer's standard
 Flanges: EN 1092-1, (DIN 2501/1972)

2. Weld ends

Face-to-face dimensions: according to the manufacturer's standard
 Dimensions of welding ends: DIN 3239 – part 1
 Groove form: DIN 2559 – sheet 1 – form 22

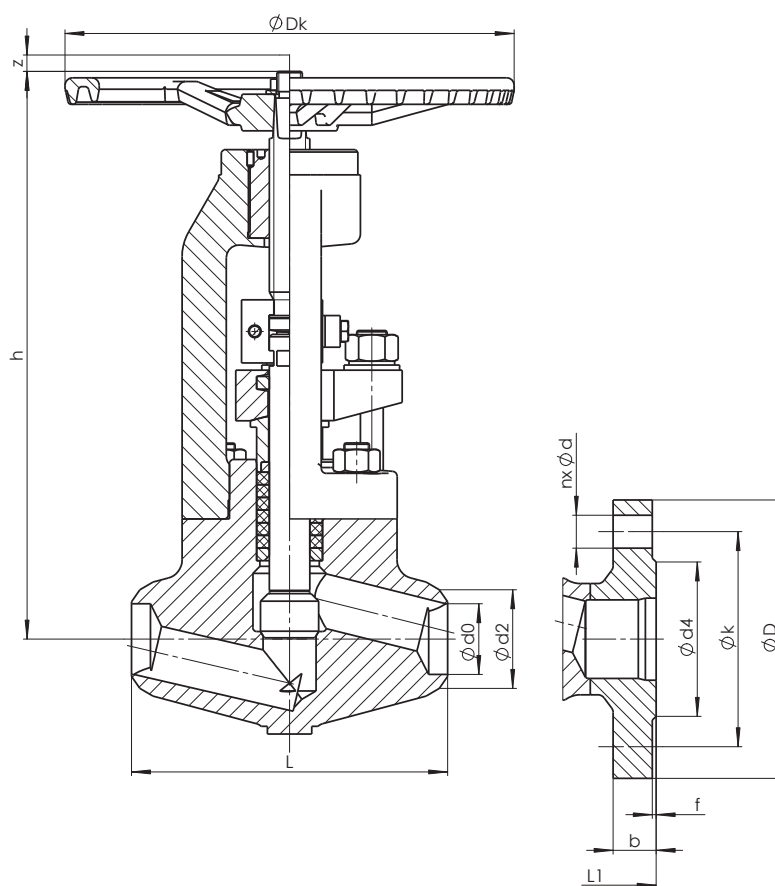

WELDING ENDS

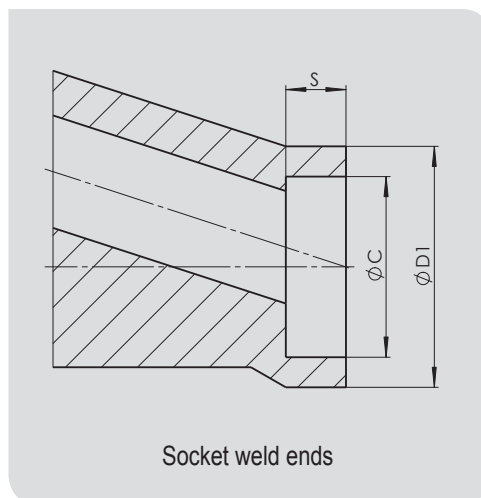
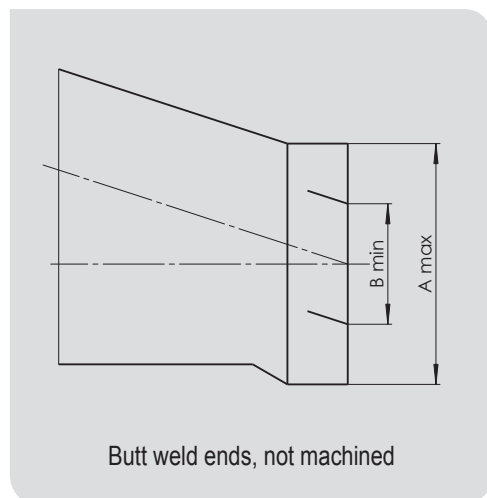

Nominal pressure	Nominal size	Centre-to-top-height	Stroke	E-actuator connection EN ISO 5210	Handwheel	Flange design							Weld ends									
													Socket weld acc. to ASME B16.11 or DIN 3239-2 PN320			Dimension of not machined butt weld ends		Approximate weight	Pipe dimension			
PN	DN	h [mm]	z [mm]	-	Dk [mm]	L1 [mm]	n	d [mm]	k [mm]	D [mm]	b [mm]	d4xf [mm]	L [mm]	d2 [mm]	d0 [mm]	D1 _{-0,5} [mm]	C ^{+0,2} [mm]	s _{min} [mm]		A _{max} [mm]	B _{min} [mm]	m [kg]
320	10	230	13	F10C	200	260	4	18	85	125	24	40x2	150	18	12	27	17,6	9,5	32	9	8,8	17,2x2,6
	15	230	13	F10C	200	260	4	18	90	130	26	45x2	150	22	15	32,5	21,7	9,5	32	14	8,5	21,3x3,2
	20	270	18	F10C	250	-	-	-	-	-	-	-	160	28	20	39,5	27,1	12,7	50	19	14,5	26,9x4,0
	25	270	18	F10C	250	300	4	22	115	160	34	68x2	160	34	24	48	33,8	12,7	50	22	14	33,7x5,0
	40	450	30	F14C	355	400	4	26	145	195	38	88x3	250	49	35	64,5	48,7	12,7	88	32	55	48,3x7,1
	50	450	30	F14C	355	400	8	26	160	210	42	102x3	250	67	47	73,5	61,1	15,9	88	40	54	63,5x8,8
400	10	230	13	F10C	200	260	4	18	85	125	28	40x2	150	18	10	-	-	-	32	9	8,8	17,2x3,6
	15	230	13	F10C	200	260	4	22	100	145	30	45x2	150	28	17	-	-	-	32	14	8,5	26,9x5,0
	20	270	18	F10C	250	-	-	-	-	-	-	-	160	34	20	-	-	-	50	19	14,5	32x6,3
	25	270	18	F10C	250	300	4	26	130	180	38	68x2	160	44	28	-	-	-	50	22	14	42,4x8
	40	450	30	F14C	355	400	4	30	165	220	48	88x3	250	61	40	-	-	-	88	32	55	60,3x11
	50	450	30	F14C	355	400	8	30	180	235	52	102x3	250	77	49	-	-	-	88	40	54	76,1x14,2
500	10	230	13	F10C	200	-	-	-	-	-	-	-	150	22	11,5	-	-	-	32	9	8,8	21,3x5,0
	15	230	13	F10C	200	-	-	-	-	-	-	-	150	32	16,5	-	-	-	32	14	8,5	32x8,0
	20	270	18	F10C	250	-	-	-	-	-	-	-	160	38	20	-	-	-	50	19	14,5	38x10,0
	25	270	18	F10C	250	-	-	-	-	-	-	-	160	49	23,5	-	-	-	50	22	14	48,3x12,5
	40	450	30	F14C	355	-	-	-	-	-	-	-	250	77	42	-	-	-	88	32	55	76,1x17,5
	50	450	30	F14C	355	-	-	-	-	-	-	-	250	86	45	-	-	-	88	40	54	82,5x20,0
630	10	230	13	F10C	200	-	-	-	-	-	-	-	150	22	11,5	-	-	-	32	9	8,8	21,3x5,0
	15	230	13	F10C	200	-	-	-	-	-	-	-	150	32	16,5	-	-	-	32	14	8,5	32x8,0
	20	270	18	F10C	250	-	-	-	-	-	-	-	160	38	20	-	-	-	50	19	14,5	38x10,0
	25	270	18	F10C	250	-	-	-	-	-	-	-	160	49	23,5	-	-	-	50	22	14	48,3x12,5
	40	450	30	F14C	355	-	-	-	-	-	-	-	250	77	42	-	-	-	88	32	55	76,1x17,5
	50	450	30	F14C	355	-	-	-	-	-	-	-	250	86	45	-	-	-	88	40	54	82,5x20,0
63	65	450	30	F10C	355	340	8	22	160	205	26	122x3	250	78	69	80,5	61,1	15,9	88	50	53	76,1x3,6
100		450	30	F10C	355	340	8	26	170	220	30	122x3	250	78	69	80,5	61,1	15,9	88	50	53	76,1x3,6
160		450	30	F14C	355	340	8	26	170	220	34	122x3	250	78	65	80,5	61,1	15,9	88	50	53	76,1x5,6
250		450	30	F14C	355	340	8	26	180	230	42	122x3	250	78	59,5	80,5	61,1	15,9	88	50	53	76,1x8,8

Flange DN 20 and DN 32 - on customer request

VALVE DESCRIPTION CODE

V46.3 111-3 320-25

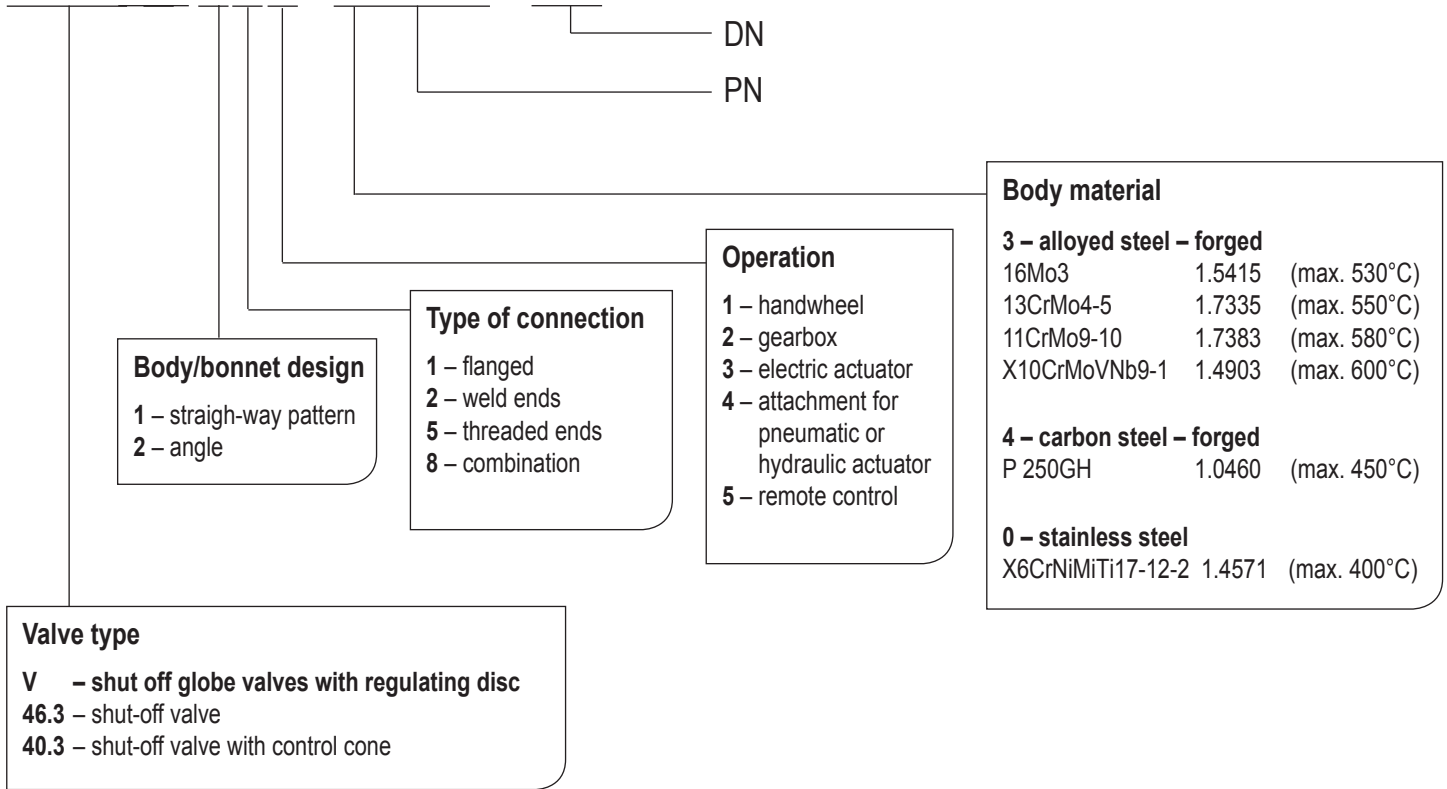

VALVE INSTALLATION

Valve can be installed in any position. Medium must flow under the cone in accordance with the direction indicated on the valve body. It is necessary to consider the following points during assembly and operation:

- operating conditions must comply with operating parameters of the valve
- proper function of the valve is affected by the presence of impurities in the pipeline and flowing medium, therefore it is necessary keep working environment a pipeline clean, for example with using filters
- the medium used must be comply with the corrosion resistance of the valve material
- use of mechanically damaged valves during the operation is prohibited

The service life of valves significantly extends regular maintenance and minor repairs carried out by trained personnel.