

LIFT CHECK VALVE WITH AUTOMATIC RELIEF Z40

PN 16-100; DN 65-150, T_{MAX}: 300°C



LIFT CHECK VALVE WITH AUTOMATIC RELIEF Z40

APPLICATION

- water, non-aggressive liquids

CONNECTION

- flanged

OPERATION

- self-acting control

DESCRIPTION

- vertical lift check valve with automatic relief
- design of the body is straight sealing
- check valve disc
- sealing surfaces are welded by hard facing (13Cr)
- complies with the requirements of the directive 2014/68/EU
- testing is carried out according to standard EN 12266-1; part 2

BASIC DESIGN OPTIONS

- according to TRD 201

SPECIFICATIONS TO BE KNOW FOR ORDER

- PN, DN
- pressure in front of the expander
- required pressure behind the expander
- required flow volume through the expander
- medium
- medium temperature

PRESSURE-TEMPERATURE-RATINGS

Material	PN	Admissible operating pressure PS [bar] at operating temperature TS [°C]						
		-10	50	100	150	200	250	300
GP240GH (1.0619)	16	16	16	14,9	13,9	12,4	11,4	10,3
	40	40	40	37,3	34,7	30,2	28,4	25,8
	63	63	63	58,8	54,6	47,6	44,8	40,6
	100	100	100	93,3	86,7	75,6	71,1	64,4

USED MATERIALS

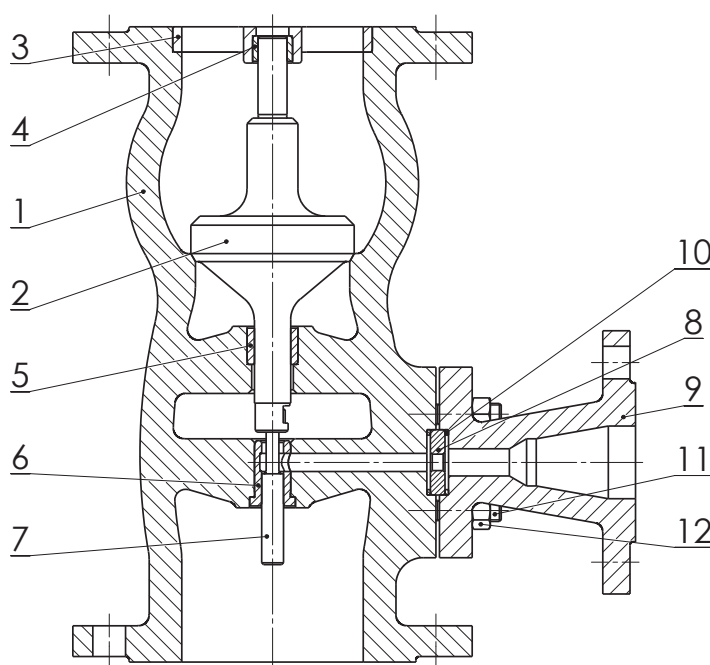

Pos.	Part	Material
1	Body	GP240GH (1.0619)
	Hard facing of sealing surface	13 Cr
2	Disc	X20Cr13 (1.4021)
3	Disk guide	11 523, P265GH (1.0425)
4, 5	Bushing	42 3018.21 (ČSN 02 3499)
6	Bushing	17 023 (1.4028)
7	Relief piston	17 029 (1.4034)
8	Orifice plate	REAL 096
9	Expander	P250GH, P265GH (1.0460, 1.0425)
10	Sealing ring	12 014
11	Bolt	25CrMo4 (1.7218)
12	Nut	C35E+QT (1.1181)

VALVE DIMENSIONS

1. Flanged

Face-to-face dimensions: EN 558 – part 1 (PN16-40), EN 558 – part 2 (PN63-100)

Flanges: EN 1092-1, (DIN 2501/1972)

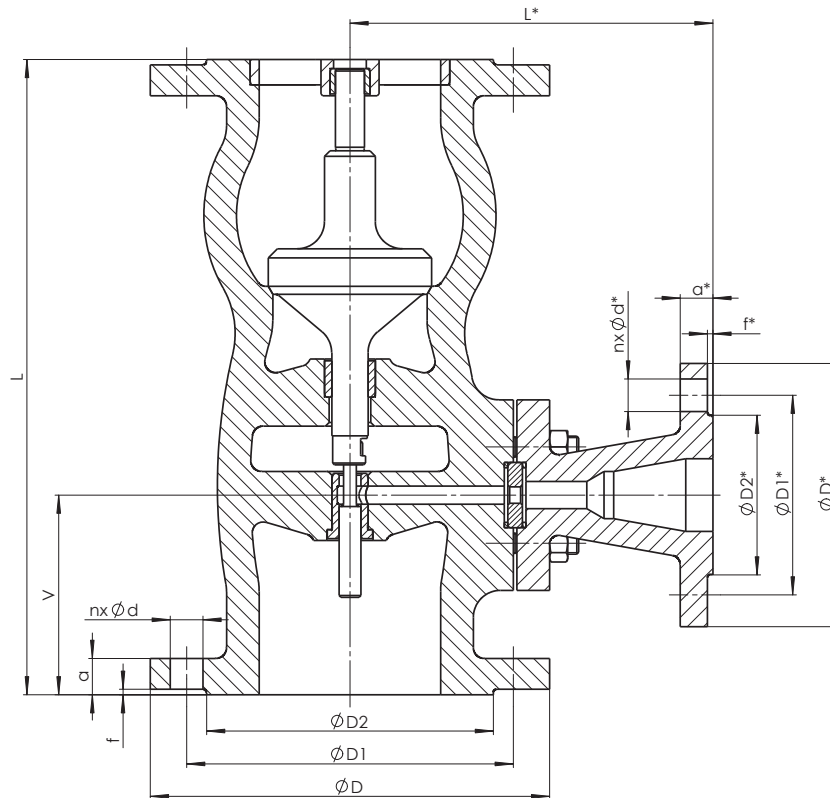



Nominal pressure	Nominal size	Face-to-face dimension	Face-to-face dimension	Disassembly height	Flanged												
					PN	DN	L [mm]	L* [mm]	V [mm]	n	d [mm]	D1 [mm]	D [mm]	a [mm]	D2×f [mm]	n	d* [mm]
16	65	290	150	90	8	18	145	185	18	122×3	4	14	85	115	18	68×2	24,0
	80	310	160	100	8	18	160	200	20	138×3	4	14	85	115	18	68×2	26,0
	100	350	200	110	8	18	180	220	20	158×3	4	18	110	145	18	88×3	41,0
	125	400	210	125	8	18	210	250	22	188×3	4	18	110	145	18	88×3	55,0
	150	480	260	160	8	22	240	285	22	212×3	8	18	145	185	22	122×3	80,0
40	65	290	150	90	8	18	145	185	22	122×3	4	14	85	115	18	68×2	24,0
	80	310	160	100	8	18	160	200	24	138×3	4	14	85	115	18	68×2	26,0
	100	350	200	110	8	22	190	235	24	162×3	4	18	110	145	18	88×3	41,0
	125	400	210	125	8	26	220	270	26	188×3	4	18	110	145	18	88×3	55,0
	150	480	260	160	8	26	250	300	28	218×3	8	18	145	185	22	122×3	80,0
63	65	340	192	110	8	22	160	205	26	122×3	4	18	100	140	24	68×2	40,0
	80	380	200	120	8	22	170	215	28	138×3	4	18	100	140	24	68×2	46,0
	100	430	215	125	8	26	200	250	30	162×3	4	22	125	170	26	88×3	64,0
	125	500	230	140	8	30	240	295	34	188×3	4	22	125	170	26	88×3	68,0
	150	550	230	190	8	33	280	345	36	218×3	8	26	170	220	30	122×3	120,0
100	65	340	192	110	8	26	170	220	30	122×3	4	18	100	140	24	68×2	45,0
	80	380	200	120	8	26	180	230	32	138×3	4	18	100	140	24	68×2	50,0
	100	430	215	125	8	30	210	265	36	162×3	4	22	125	170	26	88×3	64,0
	125	500	230	140	8	33	250	315	40	188×3	4	22	125	170	26	88×3	72,0
	150	550	230	190	12	33	290	355	44	218×3	8	26	170	220	30	122×3	136,0

VALVE DESCRIPTION CODE

Z40 117-5100-150

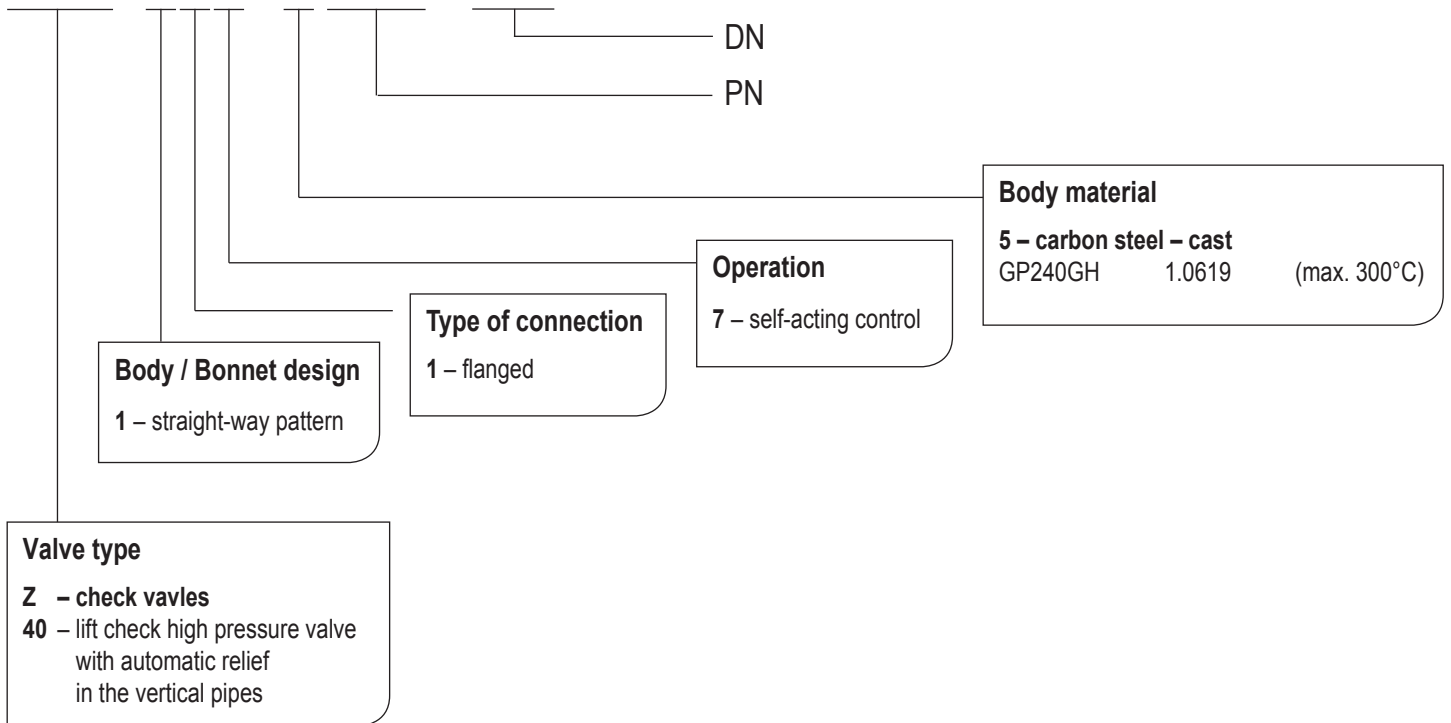

VALVE INSTALLATION

Lift check valve must be installed in the vertical position. Medium must flow under the plug in accordance with the direction indicated on the body. Installation and use of the valve following points have to be respected:

- operating conditions must comply with operating parameters of the valve
- proper function of the valve is affected by the presence of impurities in the pipeline and flowing medium, therefore it is necessary to keep the working environment and pipeline clean, for example by using filters
- medium used must comply with the corrosion resistance of the valve material
- use of mechanically damaged valves during the operation is prohibited

The service life of valves significantly extends regular maintenance and minor repairs carried out by trained personnel.