

HIGH-PRESSURE SHUT-OFF GLOBE VALVE V58/V43

PN 160–400; DN 65–150; T_{max} : 550 °C

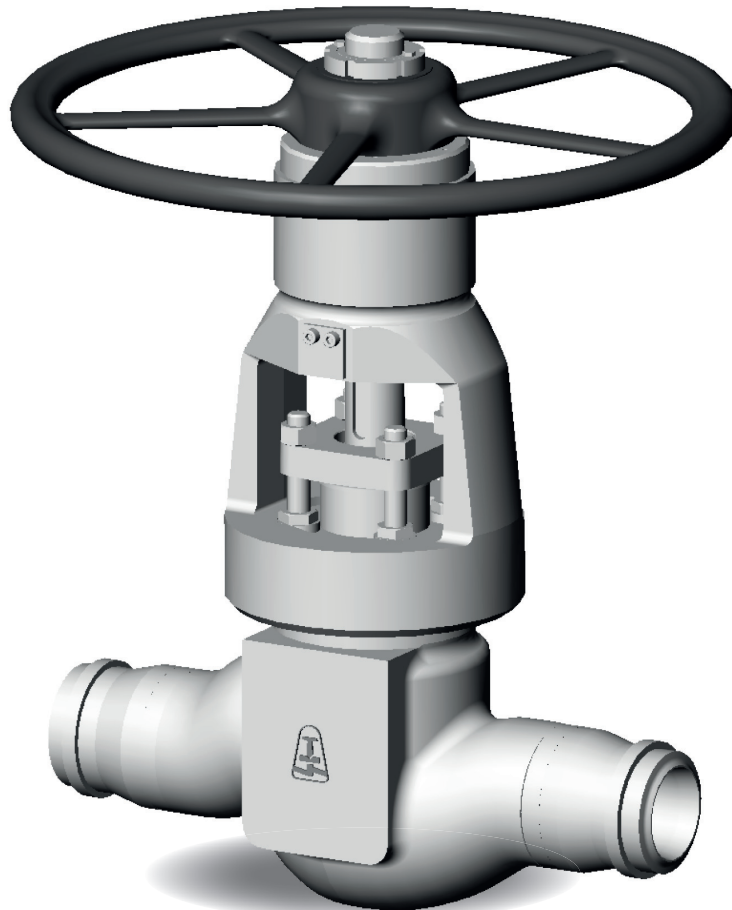

HIGH-PRESSURE SHUT-OFF GLOBE VALVE V58/V43

APPLICATION

- water, steam, gases, oils, petroleum products, non-aggressive and aggressive substances

CONNECTION

- flanged, weld ends, union nut, socket weld, combination

OPERATION

- handwheel, gearbox, electric actuator, attachment for pneumatic or hydraulic actuators, remote control

DESCRIPTION

- high-pressure shut-off globe valve V58 and high-pressure shut-off globe valve with control cone V43
- non-rotating rising stem
- one-piece body design without cover
- with straight-way body design
- conical seat
- sealing surfaces are welded by hard steel 13Cr or Stellite 6
- complies with the requirements of the directive 2014/68/EU, EN 13 709
- testing is carried out according to EN 12266-1

BASIC DESIGN OPTIONS

- control cone (for rough control) – V43
- with external by-pass (for DN 80-150 standard in closed design)
- attachment for electric actuator
- locking device

PRESSURE-TEMPERATURE-RATINGS

Material	PN	Admissible operating pressure PS [bar] at operating temperature TS [°C]																		
		-10	50	100	150	200	250	300	350	400	425	450	475	500	510	520	530	540	545	550
G17CrMo5-5 (1.7357)	160	160	160	160	160	160	160	153	143	133	129	126	111	77,6	66,4	56,8	48,8	42	39,2	36,4
	250	250	250	250	250	250	250	239	223	208	202	197	173	121	103	88,7	76,2	65,6	61,2	56,8
	320	320	320	320	320	320	320	306	286	266	259	252	222	155	132	113	97,6	84	78,4	72,8
	400	400	400	400	400	400	400	383	358	333	324	316	278	194	166	142	122	105	98	91
GP240GH (1.0619)	160	160	160	160	157	128	110	94.1	88.3	78.5	-	-	-	-	-	-	-	-	-	-
	250	250	250	250	245	196	172	147	137	123	-	-	-	-	-	-	-	-	-	-
	320	320	320	320	314	245	221	188	177	157	-	-	-	-	-	-	-	-	-	-
	400	400	400	400	392	314	275	235	221	196	-	-	-	-	-	-	-	-	-	-
GX5CrNiMo 19-11-2 (1.4408)	160	160	160	129	115	102	95	87	83	80	-	-	-	-	-	-	-	-	-	-
	250	250	250	202	180	160	148	136	130	125	-	-	-	-	-	-	-	-	-	-
	320	320	320	259	231	205	190	175	167	160	-	-	-	-	-	-	-	-	-	-
	400	400	400	323	289	257	238	219	209	200	-	-	-	-	-	-	-	-	-	-

USED MATERIALS

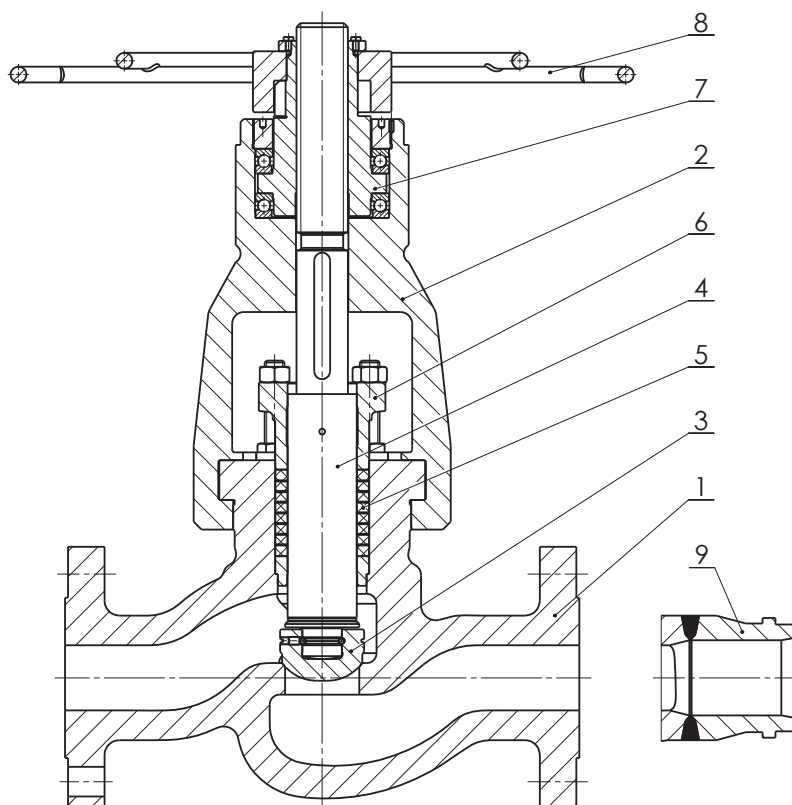

Pos.	Part	Material		
1	Body	GP240GH/1.0619	G17CrMo5-5/1.7357	GX5CrNiMo19-11-2/1.4408
	Hard facing of body sealing surface	13Cr	Stellite 6	Stellite 6
2	Yoke	G17CrMo5-5/1.7357	G17CrMo5-5/1.7357	G17CrMo5-5/1.7357
3	Disc	X20Cr13/1.4021	X22CrMoV12-1/1.4923	X6CrNiMoTi17-12-2/1.4571
	Hard facing of disc sealing surface	Hardening	Stellite 6	Stellite 6
4	Stem	X20Cr13/1.4021	X22CrMoV12-1/1.4923	X6CrNiMoTi17-12-2/1.4571
5	Gland packing	Graphite		
6	Gland	GP240GH/1.0619+N	GP240GH+N/1.0619+N	12 060.1
7	Stem nut	CuAl10Fe3Mn2/2.0936	10S20/1.0721	X6CrNiMoTi17-12-2/1.4571
8	Handwheel	EN-GJL-250/0.6025		
9	Branch	P250GH/1.0460	13CrMo4-5/1.7335	X6CrNiMoTi17-12-2/1.4571

VALVE DIMENSIONS

1. Flanged

Face-to-face dimensions: DIN 3202 – part 1 – line F2 (PN 160), line F3 (PN 250)

Flanges: EN 1092-1, (DIN 2501 – sheet 1/1972)

2. Weld ends

Face-to-face dimensions: according to standards of the manufacturer or upon the demand of the customer

Weld ends: DIN 3239 – part 1

Groove form: DIN 2559 – sheet 1 – form 22

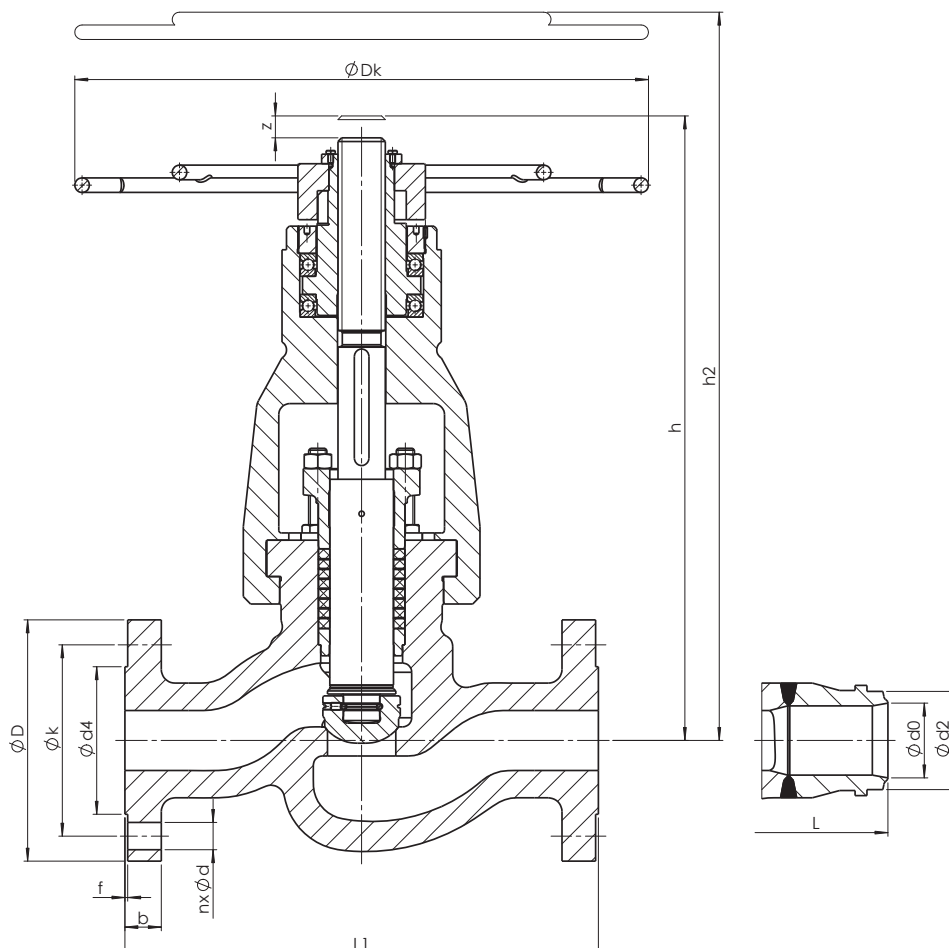

Nominal pressure	Nominal size	Stroke	Handwheel	Centre-to-top-height	Disassembly height	E-actuator connection acc. to ISO 5210	Flanged														Weld ends							
							L1	n	d	k	D	b	d4×f	m	L	d2	d0	Socket weld according to ASME B16.11, or DIN3239-2 PN320 1)			Unmachined weld ends		m	Pipe dimension				
PN	DN	z [mm]	Dk [mm]	h [mm]	h2 [mm]	-	[mm]		[mm]	[mm]	[mm]	[mm]	[mm]	[mm]	[mm]	[mm]	[mm]	D1 _{-0,5} [mm]	C ^{+0,2} [mm]	s _{min} [mm]	A _{max} [mm]	B _{min} [mm]			[kg]			
160	65	25	500	540	760	F14C	340	8	26	170	220	34	122×3	90	500	77	65	80,5	61,1	15,9	93	48	71	76,1×5,6				
	80	40	630	690	950	F16C	380	8	26	180	230	36	138×3	140	600	90	76,5	-	-	-	116	62	170	88,9×6,3				
	100	40	630	690	950	F16C	430	8	30	210	265	40	162×3	140	600	115	98,5	-	-	-	138	84	175	114,3×8				
	125	65	710	870	1160	F25C	500	8	33	250	315	44	188×3	364	900	141	120,5	-	-	-	179	106	320	139,7×10				
	150	65	710	870	1160	F25C	550	12	33	290	355	50	218×3	374	900	170	144,5	-	-	-	198	133	320	168,3×12,5				
250	65	25	500	540	760	F14C	400	8	26	180	230	42	122×3	97	500	77	59,5	80,5	61,1	15,9	93	48	71	76,1×8,8				
	80	40	630	690	950	F16C	450	8	30	200	255	46	138×3	154	600	115	93,0	-	-	-	116	62	170	2)				
	100	40	630	690	950	F25C	520	8	33	235	300	54	162×3	195	600	-	-	-	-	-	138	84	175	2)				
	125	65	710	870	1160	F25C	600	12	33	275	340	60	188×3	423	900	-	-	-	-	-	179	106	320	2)				
	150	65	710	870	1160	F25C	700	12	36	320	390	68	218×3	473	900	-	-	-	-	-	198	133	320	2)				
320	65	25	500	540	760	F16C	-	-	-	-	-	-	-	-	500	90	68,0	-	-	-	93	48	71	88,9×11				
	80	40	630	690	950	F25C	-	-	-	-	-	-	-	-	600	115	87,5	-	-	-	116	62	170	2)				
	100	40	630	690	950	F25C	-	-	-	-	-	-	-	-	600	-	-	-	-	-	138	84	175	2)				
	125	65	710	1132	1160	F30C	-	-	-	-	-	-	-	-	900	-	-	-	-	-	179	106	320	2)				
	150	65	710	1132	1160	F30C	-	-	-	-	-	-	-	-	900	-	-	-	-	-	198	133	320	2)				
400	65	25	500	540	760	F16C	-	-	-	-	-	-	-	-	500	115	81,0	-	-	-	93	48	71	2)				
	80	40	630	690	950	F25C	-	-	-	-	-	-	-	-	600	115	81,0	-	-	-	116	62	170	2)				
	100	40	630	690	950	F25C	-	-	-	-	-	-	-	-	600	-	-	-	-	-	138	84	175	2)				
	125	65	710	1132	1160	F30C	-	-	-	-	-	-	-	-	900	-	-	-	-	-	179	106	320	2)				
	150	65	710	1132	1160	F30C	-	-	-	-	-	-	-	-	900	-	-	-	-	-	198	133	320	2)				

1) Socket weld and welding ends for higher pressure as per customer request

2) As per customer specification within the dimensions Amax and Bmin

WELDING ENDS

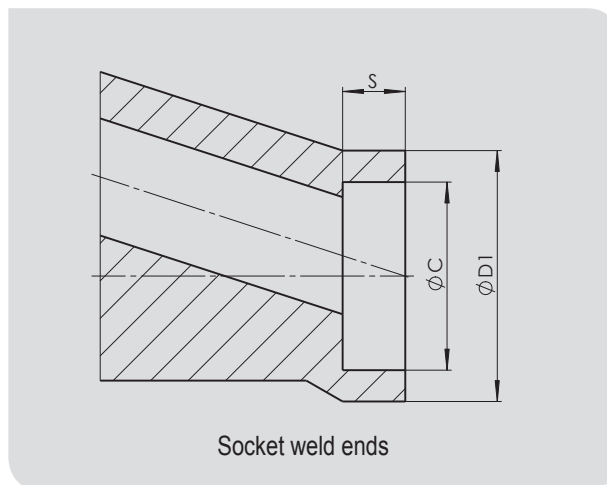
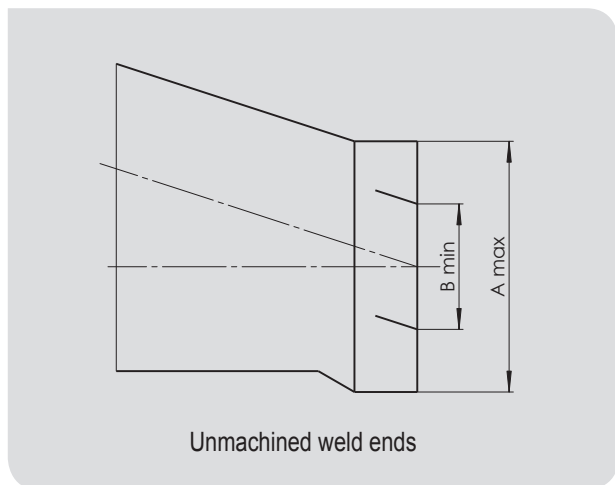

REMOTE CONTROL

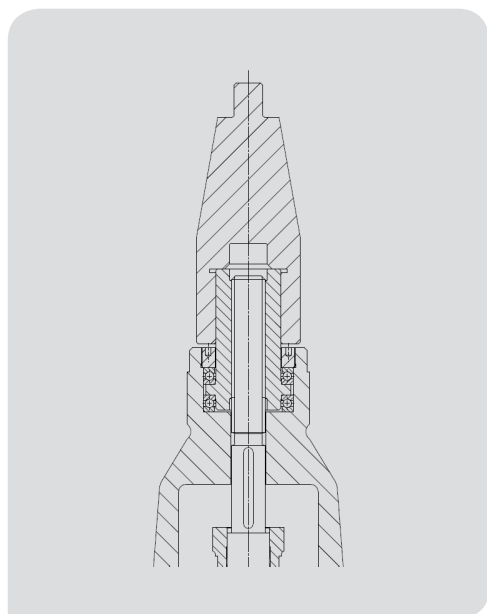

BY-PASS

CONTROL CONE

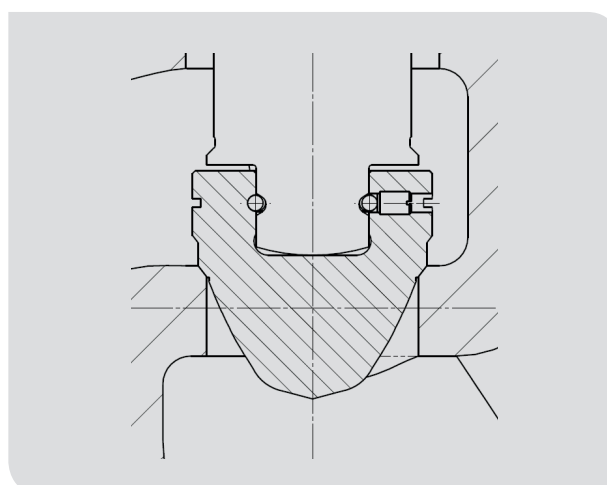
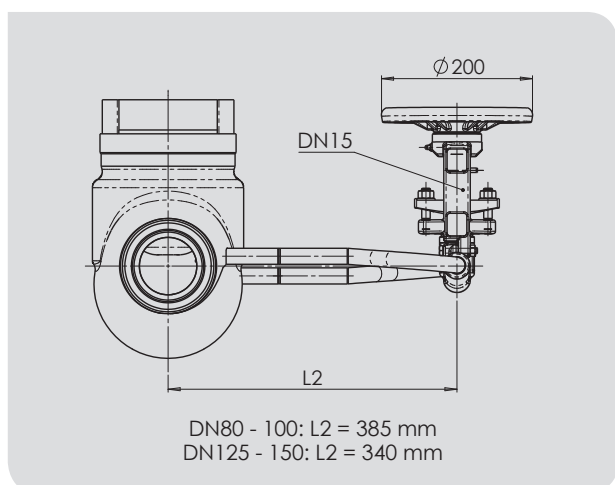

VALVE DESCRIPTION CODE

V58 111–3250–150

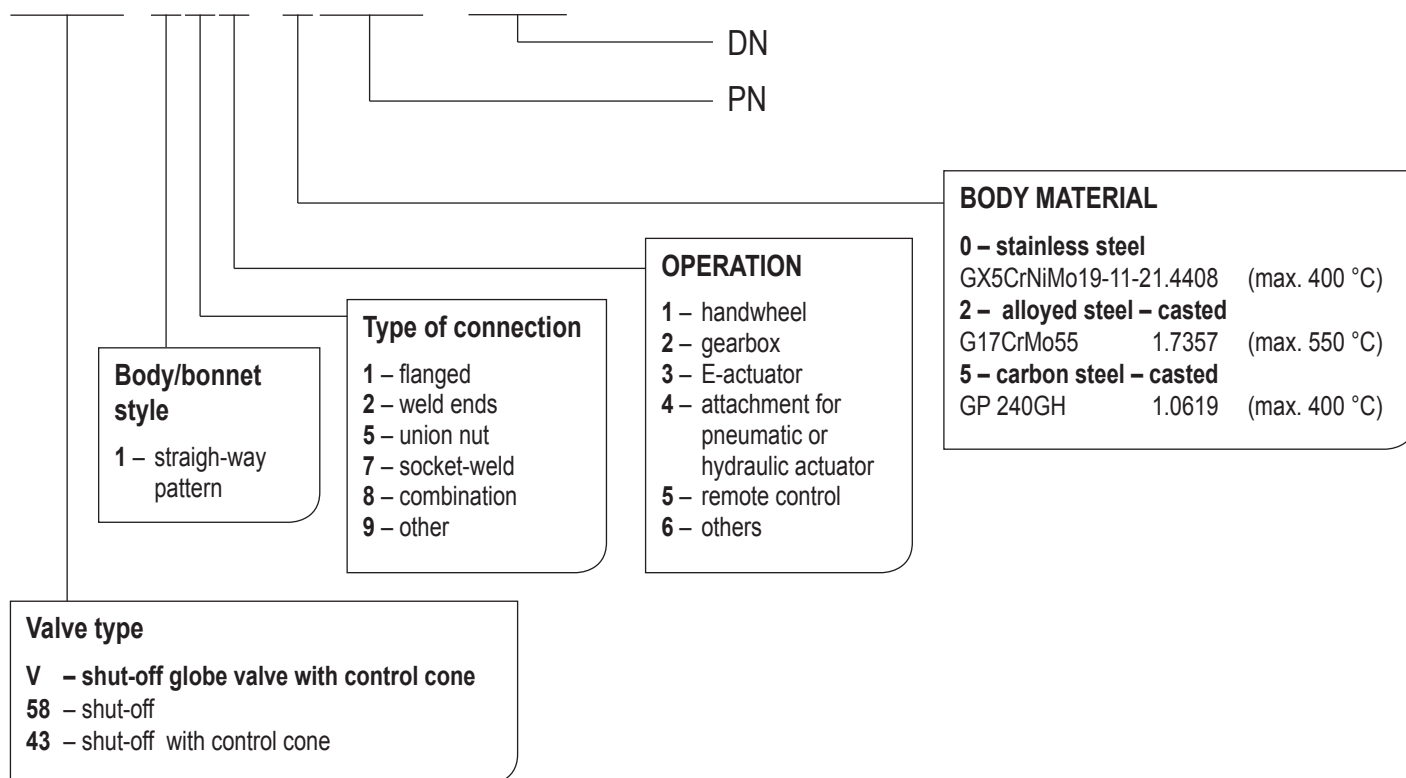

VALVE INSTALLATION

Valve can be installed in any position. Medium must flow in accordance with the direction indicated on the valve body. It is necessary to consider the following points during assembly and operation:

- operating conditions must comply with operating parameters of the valve
- proper function of the valve is affected by the presence of impurities in the pipeline and the flowing medium, therefore it is necessary keep working environment and pipeline clean, for example with using filters
- medium used must be comply with the corrosion resistance of the valve material
- use of mechanically damaged valves during the operation is prohibited

The service life of valves significantly extends regular maintenance and minor repairs carried out by trained personnel.