

STRAINER C09.2

PN 10–40; DN 15–200; T_{MAX}: 400 °C

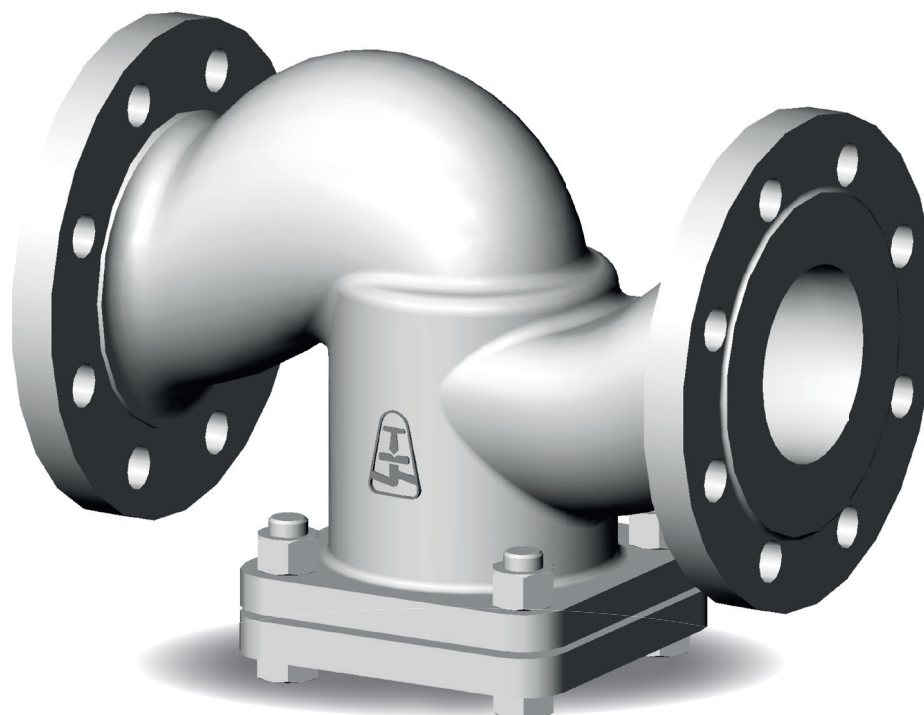

STRAINER C09.2

APPLICATION

- water, steam, non-aggressive and aggressive substances

CONNECTION

- flanged, weld ends

DESCRIPTION

- straight – way pattern
- drain plug
- complies with the requirements of the directive 2014/68/EU
- testing is carried out according to standard EN 12266-1; part 2

BASIC DESIGN OPTIONS

- filter screen – cell size and range of holes (mesh) as per customer requirement
- according to TRD 201

PRESSURE-TEMPERATURE-RATINGS

Material	PN	Admissible operating pressure PS [bar] at operating temperature TS [°C]										
		-50	-30	-10	50	100	150	200	250	300	350	400
GX5CrNiMo 19-11-2 (1.4408) ¹⁾	10	10	10	10	10	9,3	8,4	7,8	7,3	-	-	-
	16	16	16	16	16	14,9	13,5	12,4	11,7	-	-	-
	25	25	25	25	25	23,3	21,1	19,4	18,3	-	-	-
	40	40	40	40	40	37,3	33,8	31,1	29,3	-	-	-
GX5CrNi19-10 (1.4308)	10	10	10	10	9,3	8,4	7,6	6,9	6,4	-	-	-
	16	16	16	16	14,9	13,5	12,1	11	10,3	-	-	-
	25	25	25	25	23,3	21,1	18,9	17,2	16,1	-	-	-
	40	40	40	40	37,3	33,8	30,2	27,6	25,8	-	-	-
G21Mn5 (1.1138)	10	-	10	10	10	9,2	8,7	7,9	7,2	6,5	-	-
	16	-	16	16	16	14,8	14	12,8	11,8	10,8	-	-
	25	-	25	25	25	23	21	19,2	18,2	17,2	-	-
	40	-	40	40	40	37	35	32	29,5	27	-	-
GP240GH (1.0619)	10	-	-	10	10	9,3	8,7	7,8	7,1	6,4	6	5,8
	16	-	-	16	16	14,9	13,9	12,4	11,4	10,3	9,6	9,2
	25	-	-	25	25	23,3	21,7	19,4	17,8	16,1	15	14,4
	40	-	-	40	40	37,3	34,7	30,2	28,4	25,8	24	23,1

1) Application for temperatures from - 196 °C to + 250 °C on request

USED MATERIALS

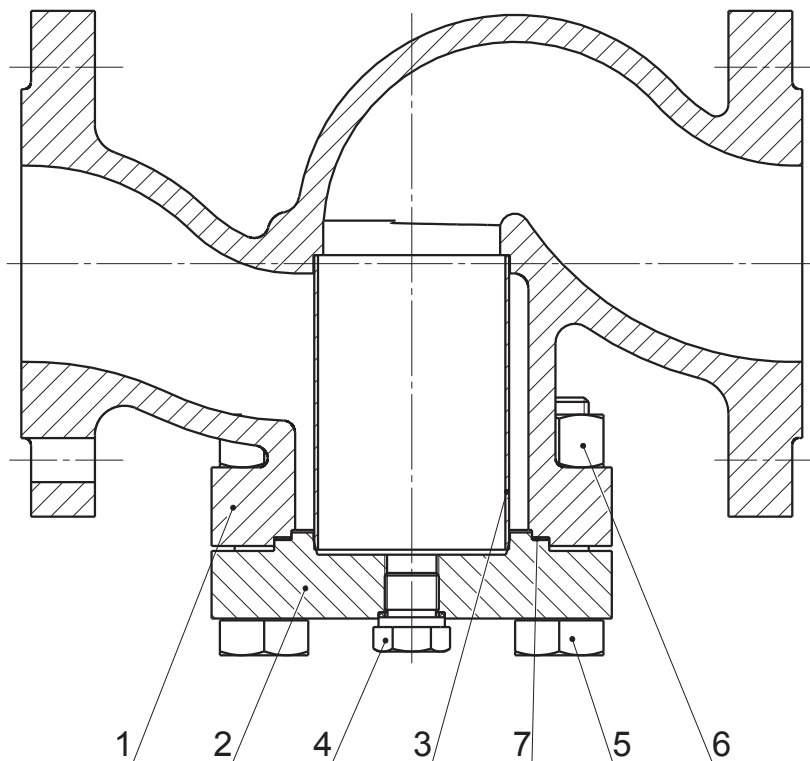

Pos.	Part	Material			
1	Body	GX5CrNiMo19-11-2 (1.4408)	GX5CrNi19-10 (1.4308)	G21Mn5 (1.1138)	GP240GH (1.0619)
2	Cover	GX5CrNiMo19-11-2, X6CrNiMoTi 17-12-2 (1.4408, 1.4571)	GX5CrNi19-10, X6CrNiMoTi 17-12-2 (1.4308, 1.4571)	G21Mn5, P265GH (1.1138, 1.0425)	GP240GH, P265GH (1.0619, 1.0425)
3	Filter screen	X5CrNi 18-10, X5CrNiMo17 12-2 (1.4301, 1.4401)			
4	Plug	X6CrNiMoTi 17-12-2 (1.4571)			
5	Bolt	A2-70			
6	Nut	A2-70			
7	Gasket	PTFE		Graphite	

VALVE DIMENSIONS

1. Flanged

Face-to-face dimensions: EN 558 – line 1
Flanges: EN 1092-1

2. Weld ends

Face-to-face dimensions: EN 12982 – line 1
Dimensions of welding ends: DIN 3239 – part 1
Groove form: DIN 2559 – sheet 1 – form 22

Other adjustments on request

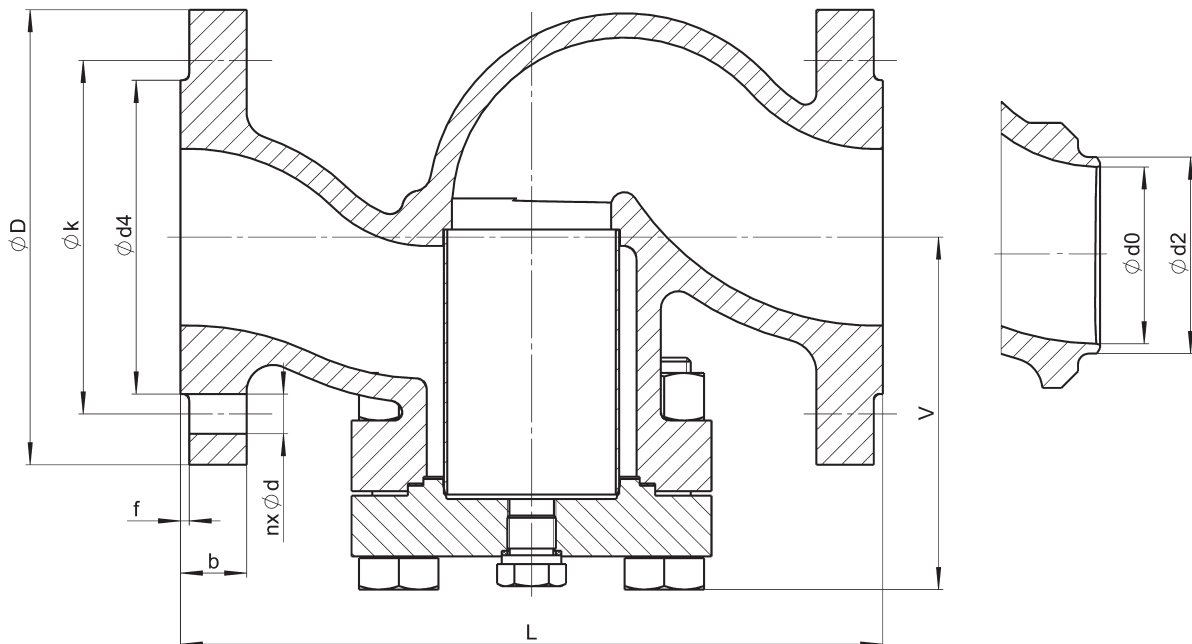

Nominal pressure	Nominal size	Face-to-face	Centre-to-top-height	Flanged							Weld ends				Filter screen ¹⁾
				PN	DN	L [mm]	V [mm]	n	d [mm]	k [mm]	D [mm]	b [mm]	d4 × f [mm]	m [kg]	
10, 16	15	130	72	4	14	65	95	16	45 × 2	2,5	22	17	-	21,3 × 2,0	0,5 × 0,32
	20	150	88	4	14	75	105	18	58 × 2	4,5	28	22	-	26,9 × 2,3	0,5 × 0,32
	25	160	88	4	14	85	115	18	68 × 2	4,5	34	28,5	-	33,7 × 2,6	0,8 × 0,5
	32	180	102	4	18	100	140	18	78 × 2	7,0	43	37	-	42,4 × 2,6	0,8 × 0,5
	40	200	112	4	18	110	150	18	88 × 3	8,0	49	43	-	48,3 × 2,6	0,8 × 0,5
	50	230	126	4	18	125	165	18	102 × 3	12,0	61	54	-	60,3 × 3,2	0,8 × 0,5
	65	290	140	8	18	145	185	18	122 × 3	15,0	77	69	10,0	76,1 × 3,6	1,25 × 0,63
	80	310	147	8	18	160	200	20	138 × 3	21,0	90	81	15,0	88,9 × 4,0	1,25 × 0,63
	100	350	178	8	18	180	220	20	158 × 3	29,0	115	104	22,0	114,3 × 5,0	1,4 × 0,71
	125	400	245	8	18	210	250	22	188 × 3	44,0	141	130,5	34,0	139,7 × 4,5	1,4 × 0,71
	150	480	285	8	22	240	285	22	212 × 3	64,0	170	156,5	51,0	168,3 × 5,6	1,4 × 0,71
10	200	600	340	8	22	295	340	24	268 × 3	142,2	222	204,5	112,0	219,1 × 7,1	1,4 × 0,71
16	200	600	340	12	22	295	340	24	268 × 3	142,0	222	204,5	112,0	219,1 × 7,1	1,4 × 0,71
25, 40	15	130	72	4	14	65	95	16	45 × 2	2,5	22	17	1,5	21,3 × 2,0	0,5 × 0,32
	20	150	88	4	14	75	105	18	58 × 2	4,5	28	22	3,0	26,9 × 2,3	0,5 × 0,32
	25	160	88	4	14	85	115	18	68 × 2	4,5	34	28,5	3,0	33,7 × 2,6	0,8 × 0,5
	32	180	102	4	18	100	140	18	78 × 2	7,0	43	37	4,0	42,4 × 2,6	0,8 × 0,5
	40	200	112	4	18	110	150	18	88 × 3	8,0	49	43	4,0	48,3 × 2,6	0,8 × 0,5
	50	230	126	4	18	125	165	20	102 × 3	12,0	61	54	8,0	60,3 × 3,2	0,8 × 0,5
	65	290	155	8	18	145	185	22	122 × 3	25,0	77	69	19,0	76,1 × 3,6	1,25 × 0,63
	80	310	160	8	18	160	200	24	138 × 3	28,0	90	81	21,0	88,9 × 4,0	1,25 × 0,63
	100	350	174	8	22	190	235	24	162 × 3	40,0	115	104	31,0	114,3 × 5,0	1,4 × 0,71
	125	400	230	8	26	220	270	26	188 × 3	55,0	141	130,5	44,0	139,7 × 4,5	1,4 × 0,71
150	480	243	8	26	250	300	28	218 × 3	76,0	170	156,5	61,0	168,3 × 5,6	1,4 × 0,71	
25	200	600	340	12	26	310	360	30	278 × 3	153,0	222	204,5	125,0	219,1 × 7,1	1,4 × 0,71
40	200	600	340	12	30	320	375	34	285 × 3	156,0	222	204,5	125,0	219,1 × 7,1	1,4 × 0,71

1) Other sizes of filter screen upon customer request

VALVE DESCRIPTION CODE

C09.2 117-540-150

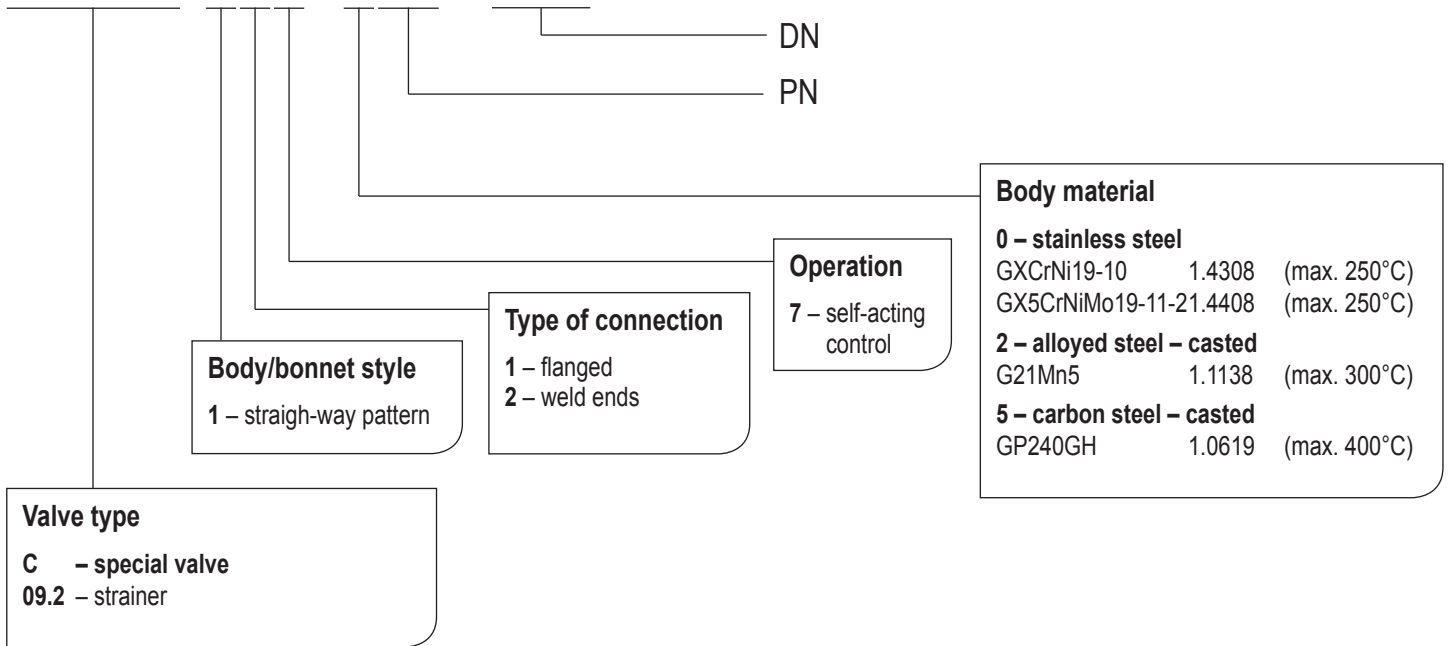

VALVE INSTALLATION

Valve must always be installed in the line position – plug down. Medium correspondence with the arrow marked on the valve body. Installation and use the valve following points have to be respected:

- operating conditions must comply with operating parameters of the valve
- proper function of the valve is affected by the presence of impurities in the filter screen. It is necessary keep the filter screen clean
- medium used must comply with the corrosion resistance of the valve material
- use of mechanically damaged valves during the operation is prohibited

The service life of valves significantly extends regular maintenance and minor repairs carried out by trained personnel.