

HIGH-PRESSURE SHUT-OFF GLOBE VALVE V30/V40

PN 63–160; DN 50–150; T_{MAX} : 550 °C

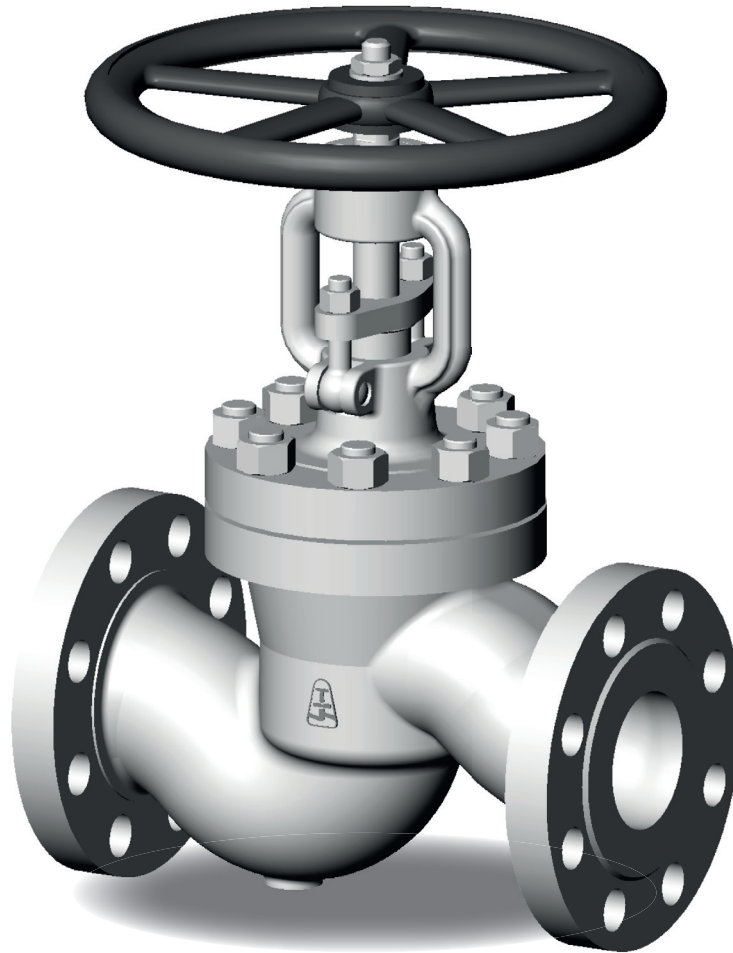

HIGH-PRESSURE SHUT-OFF GLOBE VALVE V30/V40

APPLICATION

- water, steam, gases, oils, petroleum products, non-aggressive substances

CONNECTION

- flanged, weld ends

OPERATION

- handwheel, gearbox, electric actuator, attachment for pneumatic or hydraulic actuator, remote control

DESCRIPTION

- shut-off globe valve V30 and shut-off globe valve with control cone V40
- the shape of the body is straight
- rotating rising stem
- flanged or welded design
- with handwheel
- sealing surfaces are welded by hard steel or stellite
- complies with the requirements of the directive 2014/68/EU, EN 13 709
- testing is carried out according to EN 12266-1

BASIC DESIGN OPTIONS

- control cone (for rough control) – series V40
- attachment for electric actuator
- by-pass (balanced disk) for DN 65-150
- branch from forged steel – on request
- position indicator
- limit switches
- PTFE – gland packing and bonnet gasket
- locking device
- according to TRD 201

PRESSURE-TEMPERATURE-RATINGS

Material	PN	Admissible operating pressure PS [bar] at operating temperature TS [°C]																
		-10	50	100	150	200	250	300	350	400	450	475	500	510	520	530	540	550
GX5CrNiMo 19-11-2 (1.4408)	63	63	63	47,3	42,1	37,4	32,3	25,4	20,3	16,7	-	-	-	-	-	-	-	-
	100	100	100	75	66,9	59,4	51,3	40,3	32,3	26,5	-	-	-	-	-	-	-	-
	-	-	-	-	-	-	-	-	-	-	-	-	-	-	-	-	-	-
GP240GH (1.0619)	63	63	63	59	55	48	45	41	38	36	35	-	-	-	-	-	-	-
	100	100	100	93	87	76	71	64	60	58	55	-	-	-	-	-	-	-
	160	160	160	149	136	124	113	103	96	92	89	-	-	-	-	-	-	-
G17CrMo5-5 (1.7357)	63	63	63	63	63	63	62	57	53	51	48	47	38	33	26	24,4	18,1	13,7
	100	100	100	100	100	100	98	91	84	80	76	75	61	52	42	38,7	28,7	21,8
	160	160	160	160	160	160	160	160	152	146	139	127	118	97	79	62	46	35

USED MATERIALS

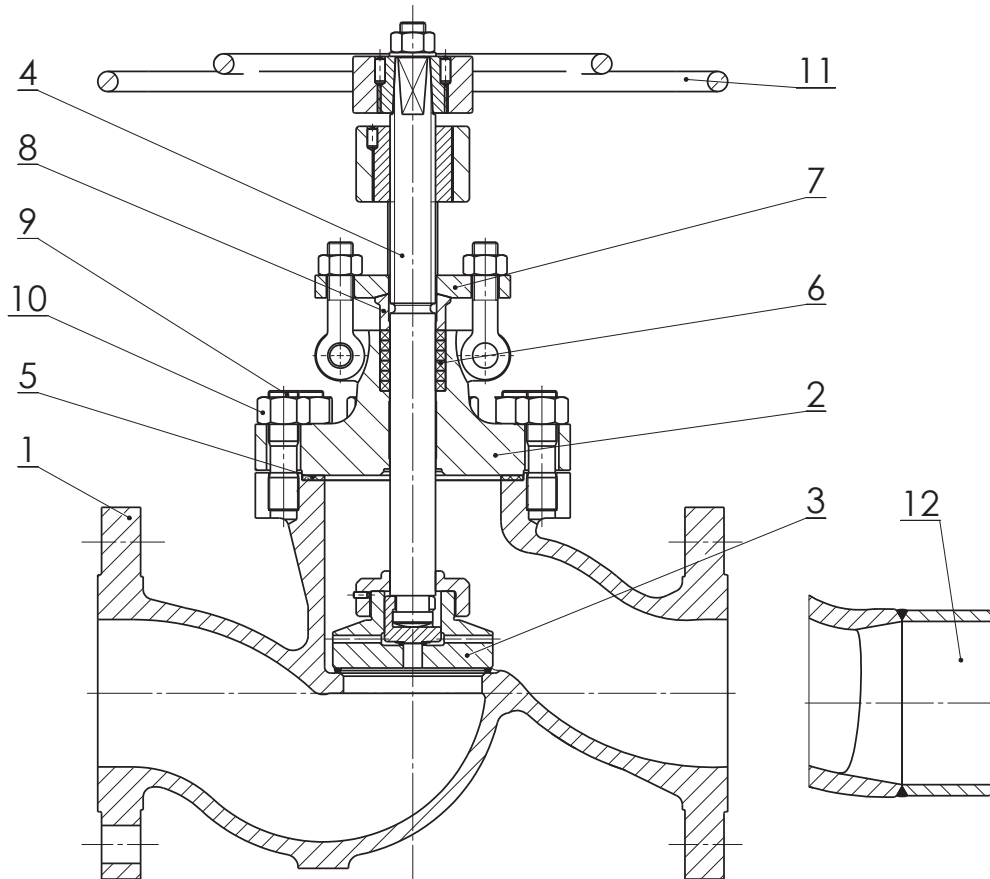

Pos.	Part	Material		
1	Body	GP240GH (1.0619)	G17CrMo5-5 (1.7357)	GX5CrNiMo19-11-2 (1.4408)
	Hard facing of sealing surface	13Cr	Stellite 6	Stellite 6
2	Yoke	GP240GH (1.0619)	G17CrMo5-5 (1.7357)	GX5CrNiMo19-11-2 (1.4408)
3	Disc	P250GH (1.0460)	X22CrMoV12-1 (1.4923)	X6CrNiMoTi17-12-2 (1.4571)
	Hard facing of sealing surface	13Cr	Stellite 6	Stellite 6
4	Stem	X20Cr13 (1.4021)	X22CrMoV12-1 (1.4923)	X6CrNiMoTi17-12-2 (1.4571)
5	Gasket	Graphite Kammprofil		
6	Gland packing	Graphite		
7	Gland flange	P265GH (1.0425)	P265GH (1.0425)	X6CrNiMoTi17-12-2 (1.4571)
8	Gland	P250GH (1.0460)	P250GH (1.0460)	X6CrNiMoTi17-12-2 (1.4571)
9	Bolt	21CrMoV5-7 (1.7709)	21CrMoV5-7 (1.7709)	A2-70
10	Nut	25CrMo4 (1.7218)	21CrMoV5-7 (1.7709)	A2-70
11	Handwheel	EN-GJS-400-15 (0.7040) / 11523.0		
12	Branch	P250GH; 16Mo3 (1.0460; 1.5415)	16Mo3; 13CrMo4-5 (1.5415; 1.7335)	X6CrNiMoTi17-12-2 (1.4571)

VALVE DIMENSIONS

1. Flanged

Face-to-face dimensions: EN 558 – line 1
 Flanges: EN 1092-1

2. Weld ends

Face-to-face dimensions: EN 12982 – line 65 (DIN3202 – 2/S3), DN50 = 260mm
 Face-to-face dimensions with branches: as per table (Lb) or on request
 Dimensions of welding ends: DIN 3239 – part 1
 Groove form: DIN 2559 – sheet 1 – form 22

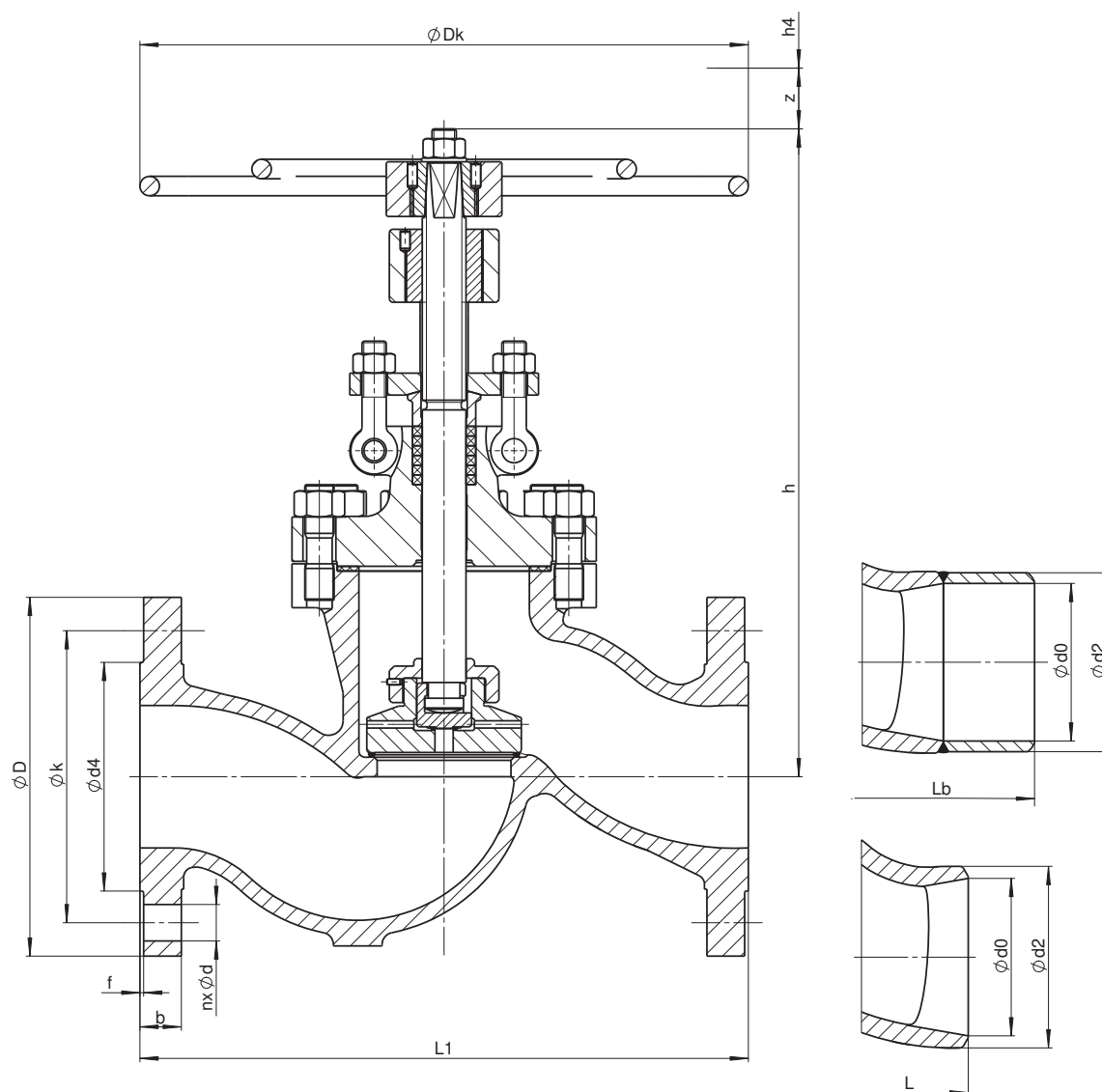

Nominal pressure	Nominal size	Stroke	Handwheel	Centre-to-top	Dismantling height	Flanged								Weld ends					
						PN	DN	z [mm]	Dk [mm]	h [mm]	h4 [mm]	L1 [mm]	n	d [mm]	k [mm]	D [mm]	b [mm]	d4xf [mm]	m [kg]
63	50	47	250	360	140	300	4	22	135	180	26	102×3	32	260	400	61	54	24	60,3×3,2
	65	34	315	408	170	340	8	22	160	205	26	122×3	45	340	480	77	69	36	76,1×3,6
	80	64	400	459	190	380	8	22	170	215	28	138×3	57	380	520	90	81	49	88,9×4,0
	100	71	400	484	200	430	8	26	200	250	30	162×3	83	430	570	115	104	71	114,3×5,0
	125	85	500	538	230	500	8	30	240	295	34	188×3	110	500	650	141	130,5	84	139,7×4,5
	150	95	500	580	260	550	8	33	280	345	36	218×3	170	550	710	170	156,5	118	168,3×5,6
100	50	47	250	360	140	300	4	26	145	195	28	102×3	34	260	400	61	54	25	60,3×3,2
	65	34	315	408	170	340	8	26	170	220	30	122×3	49	340	480	77	69	36	76,1×3,6
	80	64	400	459	190	380	8	26	180	230	32	138×3	63	380	520	90	81	49	88,9×4,0
	100	71	400	484	200	430	8	30	210	265	36	162×3	94	430	570	115	104	71	114,3×5,0
	125	85	500	538	230	500	8	33	250	315	40	188×3	123	500	650	141	127	90	139,7×6,3
	150	95	500	580	260	550	12	33	290	355	44	218×3	181	550	710	170	154	129	168,3×7,1
160	50	47	250	360	140	300	4	26	145	195	30	102×3	35	260	400	61	52,5	26	60,3×4
	65	34	315	408	170	340	8	26	170	220	34	122×3	50	340	480	77	65	37	76,1×5,6
	80	64	400	459	190	380	8	26	180	230	36	138×3	64	380	520	90	76,5	50	88,9×6,3
	100	71	400	484	200	430	8	30	210	265	40	162×3	95	430	570	115	98,5	72	114,3×8
	125	85	500	538	230	500	8	33	250	315	44	188×3	125	500	650	141	120,5	92	139,7×10
	150	95	630	580	260	550	12	33	290	355	50	218×3	183	550	710	170	144,5	131	168,3×12,5

DESIGN VARIANTS

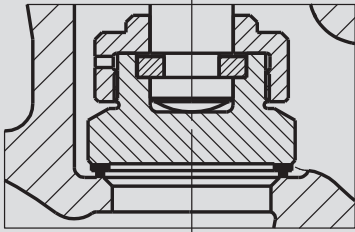

V 30 DN 50

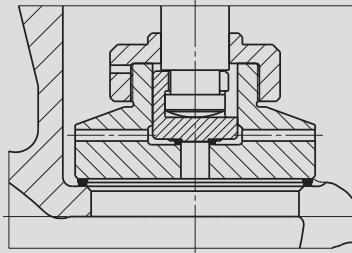

V 30 DN65..150

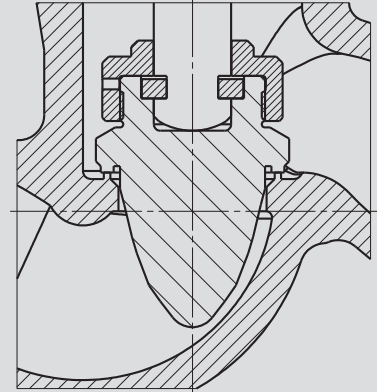

V40...DN50..65

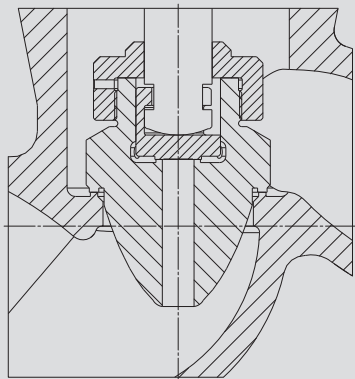

V40 DN80...150

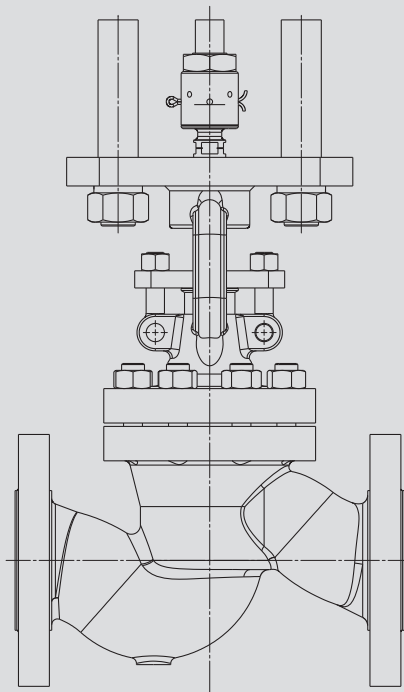

attachment with traction electric actuator

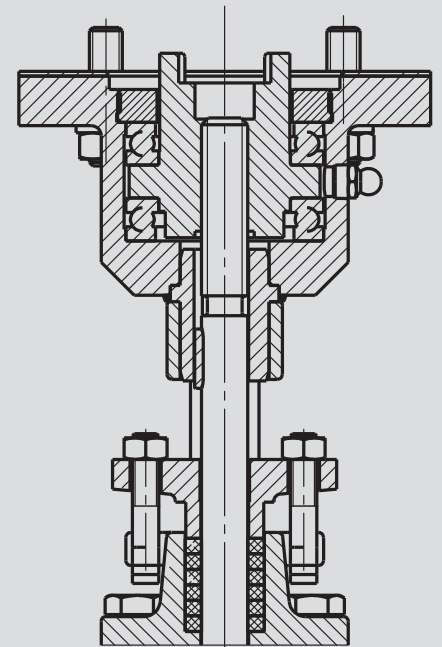

attachment for rotary electric actuator

VALVE DESCRIPTION CODE

V30 111–2160–100

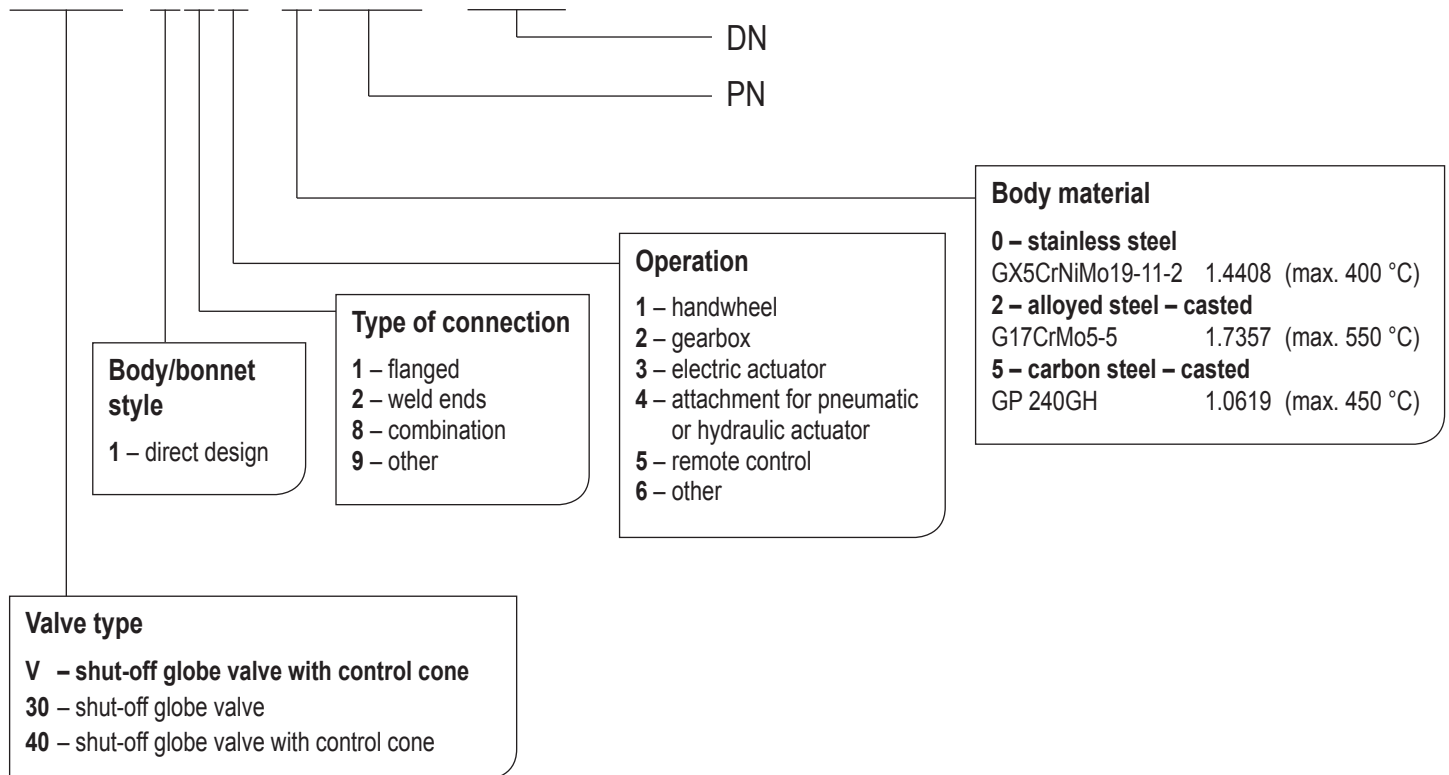

VALVE INSTALLATION

Valve can be installed in any position. Medium must flow in accordance with the direction indicated on the body. It is necessary to consider the following points during assembly and operation:

- operating conditions must comply with operating parameters of the valve
- proper function of the valve is affected by the presence of impurities in the pipeline and flowing medium, therefore it is necessary keep working environment a pipeline clean, for example with using filters
- medium used must comply with the corrosion resistance of the valve material
- use of mechanically damaged valves during the operation is prohibited

The service life of valves significantly extends regular maintenance and minor repairs carried out by trained personnel.