

HIGH-PRESSURE STRAINER D30

PN 63–160; DN 50–150, T_{MAX} : 550°C

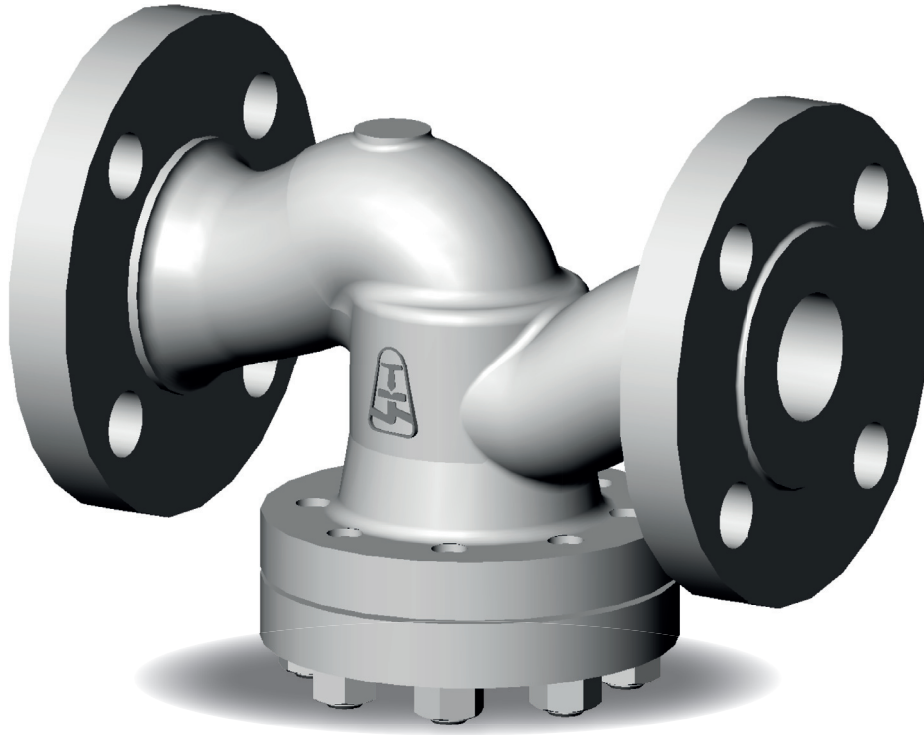

HIGH-PRESSURE STRAINER D30

APPLICATION

- water, steam, gases, oils, petroleum products, non-aggressive substances

CONNECTION

- flanged, weld ends

OPERATION

- without operation

DESCRIPTION

- direct design
- drain plug
- strainer – standart range of holes (mesh)
23 to 600 meshes/inch
- complies with the requirements of the directive 2014/68/EU
- testing is carried out according to EN 12266-1

BASIC DESIGN OPTIONS

- welding ends from forged materials
- according to TRD 201

PRESSURE-TEMPERATURE-RATINGS

Material	PN	Admissible operating pressure PS [bar] at operating temperature TS [°C]																
		-10	50	100	150	200	250	300	350	400	450	475	500	510	520	530	540	550
GP240GH (1.0619)	63	63	63	59	55	48	45	41	38	36	35	-	-	-	-	-	-	-
	100	100	100	93	87	76	71	64	60	58	55	-	-	-	-	-	-	-
	160	160	160	149	136	124	113	103	96	92	89	-	-	-	-	-	-	-
G17CrMo5-5 (1.7357)	63	63	63	63	63	63	62	57	53	51	48	47	38	33	26	24,4	18,1	13,7
	100	100	100	100	100	100	98	91	84	80	76	75	61	52	42	38,7	28,7	21,8
	160	160	160	160	160	160	160	160	152	146	139	127	118	97	79	62	46	35

USED MATERIALS

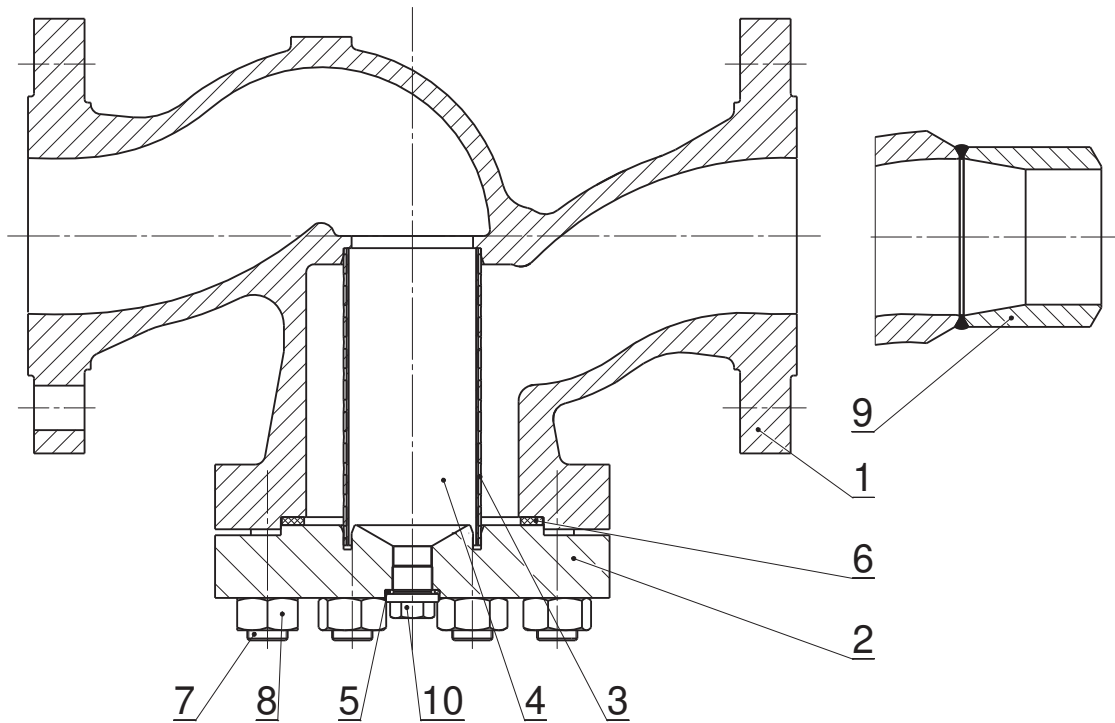

Pos.	Part	Material	
1	Body	GP240GH (1.0619)	G17CrMo5-5 (1.7357)
2	Cover	13CrMo4-5 (1.7335)	
3, 4	Strainer	X5CrNi18-10 (1.4301)	
5	Gasket	ST/Isoplán	
6	Gasket	Grafit	
7	Bolt	21CrMoV5-7 (1.7709)	
8	Nut	25CrMo4 (1.7218)	21CrMoV5-7 (1.7709)
9	Branch	P250GH; 16Mo3 (1.0460; 1.5415)	16Mo3; 13CrMo4-5 (1.5415; 1.7335)
10	Plug	21CrMoV5-7 (1.7709)	

VALVE DIMENSIONS

1. Flanged

Face-to-face dimensions:

EN 558 – line 2

Flanges:

EN 1092-1

2. Weld ends

Face-to-face dimensions:

as per table EN 12 982 – line 65 DIN 3202 – part2 – line S3, DN50 = 260 mm

Face-to-face dimensions with branches:

as per table (Lb) or on request

Dimensions of welding ends:

DIN 3239 – part 1

Groove form:

DIN 2559 – sheet 1 – form 22

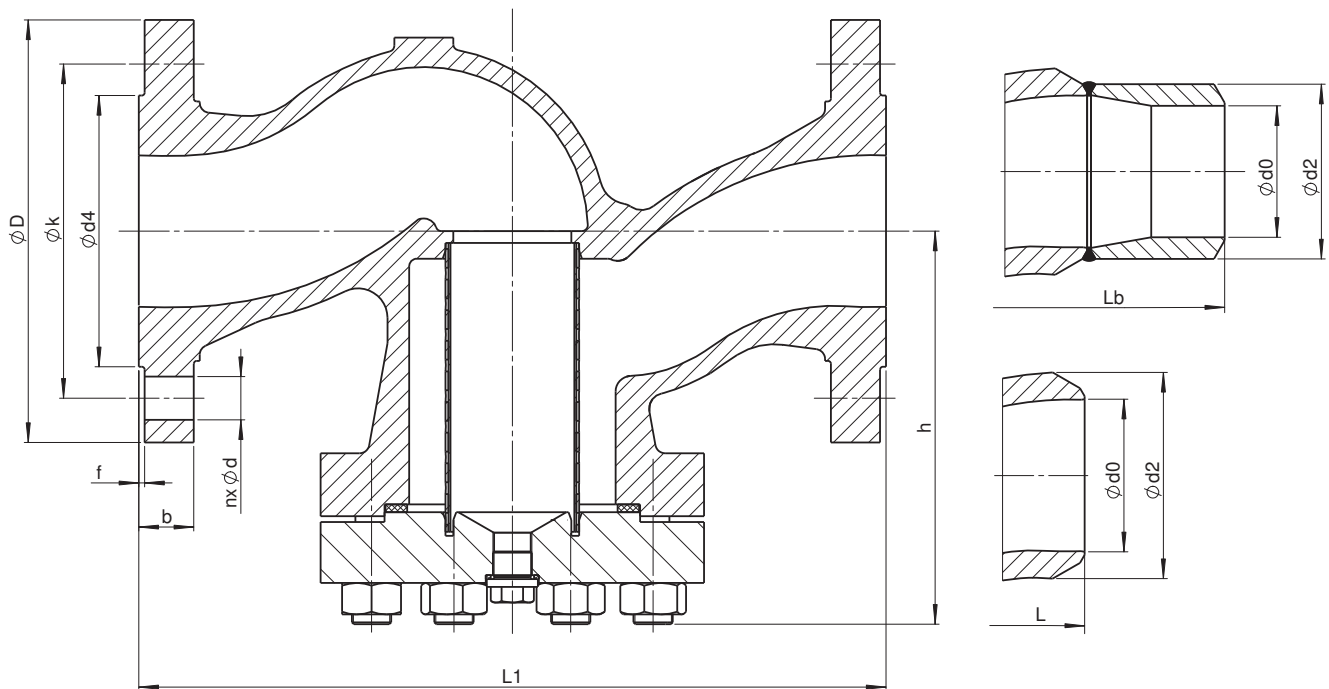

Nominal pressure	Nominal size	Centre-to-top-height	Flanged									Weld ends					Filter screen ¹⁾
			PN	DN	h [mm]	L1 [mm]	n	d [mm]	k [mm]	D [mm]	b [mm]	d4xf [mm]	m [kg]	L [mm]	Lb [mm]	d2 [mm]	
63	50	150	300	4	22	135	180	26	102×3	24	260	400	61	54	14	60,3×3,2	0,4×0,23
	65	175	340	8	22	160	205	26	122×3	35	340	480	77	69	25	76,1×3,6	0,4×0,23
	80	200	380	8	22	170	215	28	138×3	42	380	520	90	81	31	88,9×4,0	0,4×0,23
	100	225	430	8	26	200	250	30	162×3	63	430	570	115	104	48	114,3×5,0	0,4×0,23
	125	240	500	8	30	240	295	34	188×3	87	500	650	141	130,5	62	139,7×4,5	1×0,5
	150	275	550	8	33	280	345	36	218×3	140	550	710	170	156,5	83	168,3×5,6	1,6×0,5
100	50	150	300	4	26	145	195	28	102×3	26	260	400	61	54	14	60,3×3,2	0,4×0,23
	65	175	340	8	26	170	220	30	122×3	39	340	480	77	69	25	76,1×3,6	0,4×0,23
	80	200	380	8	26	180	230	32	138×3	49	380	520	90	81	31	88,9×4,0	0,4×0,23
	100	225	430	8	30	210	265	36	162×3	74	430	570	115	104	48	114,3×5,0	0,4×0,23
	125	240	500	8	33	250	315	40	188×3	101	500	650	141	127	62	139,7×6,3	1×0,5
	150	275	550	12	33	290	355	44	218×3	144	550	710	170	154	83	168,3×7,1	1,6×0,5
160	50	150	300	4	26	145	195	30	102×3	28	260	400	61	52,5	15	60,3×4	0,4×0,23
	65	175	340	8	26	170	220	34	122×3	43	340	480	77	65	26	76,1×5,6	0,4×0,23
	80	200	380	8	26	180	230	36	138×3	53	380	520	90	76,5	32	88,9×6,3	0,4×0,23
	100	225	430	8	30	210	265	40	162×3	78	430	570	115	98,5	49	114,3×8	0,4×0,23
	125	240	500	8	33	250	315	44	188×3	105	500	650	141	120,5	63	139,7×10	1×0,5
	150	275	550	12	33	290	355	50	218×3	149	550	710	170	144,5	84	168,3×12,5	1,6×0,5

1) Other sizes of filter screen upon customer request

VALVE DESCRIPTION CODE

D30 118–2100–50

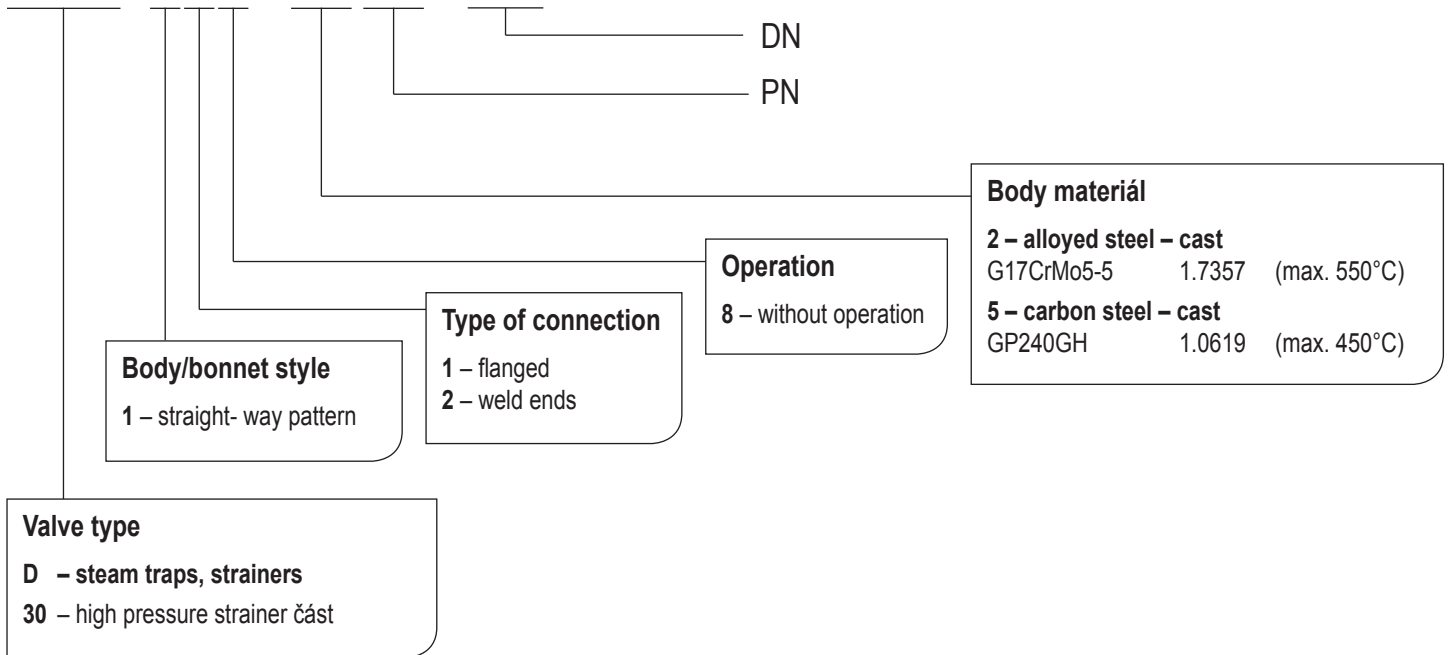

VALVE INSTALLATION

Valve must always be installed in the line position – plug down. Medium correspondence with the arrow marked on the valve body. Installation and use the valve following points have to be respected:

- operating conditions must comply with operating parameters of the valve
- proper function of the valve is affected by the presence of impurities in the pipeline and flowing medium
- medium used must comply with the corrosion resistance of the valve materiál
- use of mechanically damaged valves during the operation is prohibited

The service life of valves significantly extends regular maintenance and minor repairs carried out by trained personnel.