

HIGH-PRESSURE SHUT-OFF GLOBE VALVE V46.2/V40.2

PN 63–500; DN 10–65; T_{MAX} : 600 °C



HIGH-PRESSURE SHUT-OFF GLOBE VALVE V46.2/V40.2

APPLICATION

- water, steam, gas, oils, petroleum products, non-aggressive and aggressive substances

CONNECTION

- flanged, weld ends, socket weld, threaded ends, combination

OPERATION

- handwheel, gearbox, electric actuator, attachment for pneumatic or hydraulic actuator, remote control

DESCRIPTION

- high-pressure shut-off valve V46.2 and high-pressure shut-off valve with control cone V40.2
- non-rotating rising stem
- one-piece stem with throttle cone
- one-piece forged body without cover
- stem gland packing in body
- sealing surfaces are welded by hard steel (13Cr) or Stellite 6
- conical seat
- position indicator
- complies with the requirements of the directive 2014/68/EU and standard EN 13 709
- testing is carried out according to standard EN 12266-1; part 2

BASIC DESIGN OPTIONS

- according to TRD 201
- locking device
- limit switches
- gland with scraper ring

PRESSURE-TEMPERATURE-RATINGS

Material	PN	Admissible operating pressure PS [bar] at operating temperature TS [°C]																
		-10	50	100	150	200	250	280	300	350	380	390	400	410	420	430	440	450
P250GH (C22.8) (1.0460)	63	63	63	63	63	63	56,7	53,2	50,4	44,9	41,0	40,2	39,4	38,4	37,5	36,5	35,6	34,7
	100	100	100	100	100	100	90,0	84,5	80,0	71,3	65,0	63,8	62,5	61,0	59,5	58,0	56,5	55,0
	160	160	160	160	160	160	144	135	128	114	104	102	100	97,6	95,2	92,8	90,4	88,0
	250	250	250	250	250	250	225	212	200	178	163	159	156	153	149	145	141	138
	320	320	320	320	320	320	288	271	256	228	208	204	200	195	190	186	181	176
	400	400	400	400	400	400	360	340	320	285	260	255	250	244	238	232	226	220

Material	PN	Admissible operating pressure PS [bar] at operating temperature TS [°C]																	
		-10	200	250	300	350	400	450	475	490	500	510	520	530	540	550	575	580	600
16Mo3 (1.5415)	63	63	63	63	63	59	56,7	52,9	50,4	44,1	36,5	25,7	20,4	16,3	-	-	-	-	-
	100	100	100	100	100	94	90	84	80	70	58	40,8	32,4	25,8	-	-	-	-	-
	160	160	160	160	160	151	144	134	128	112	92,8	65,3	51,8	41,3	-	-	-	-	-
	250	250	250	250	250	238	225	210	200	175	145	102	81	64,5	-	-	-	-	-
	320	320	320	320	320	302	288	268,8	256	224	186	131	104	82,6	-	-	-	-	-
	400	400	400	400	400	379	360	336	320	280	232	163	130	103	-	-	-	-	-
	500	500	500	500	500	473	450	420	400	350	290	204	162	129	-	-	-	-	-

Material	PN	Admissible operating pressure PS [bar] at operating temperature TS [°C]																	
		-10	200	250	300	350	400	450	475	490	500	510	520	530	540	550	570	580	600
13CrMo4-5 (1.7335)	63	63	63	63	63	63	63	56,7	55,3	52,3	50,4	40,3	32,8	27,1	21,2	17,0	10,5	-	-
	100	100	100	100	100	100	100	90	87,8	83	80	64	52,0	43,0	33,6	27,0	16,6	-	-
	160	160	160	160	160	160	160	144	140	133	128	102	83,2	68,8	53,8	43,2	26,6	-	-
	250	250	250	250	250	250	250	225	220	208	200	160	130	108	84	67,5	41,5	-	-
	320	320	320	320	320	320	320	288	281	266	256	205	166	138	108	86,4	53,1	-	-
	400	400	400	400	400	400	400	360	351	332	320	256	208	172	134	108	66,4	-	-
	500	500	500	500	500	500	500	450	439	415	400	320	260	215	168	135	83,0	-	-

Material	PN	Admissible operating pressure PS [bar] at operating temperature TS [°C]																	
		-10	200	250	300	350	400	450	475	490	500	510	520	530	540	550	575	580	600
11CrMo9-10 (1.7383)	63	63	63	63	63	63	63	56,7	54,2	51,7	50,4	40,3	35,3	30,2	26,5	22,7	16,4	15,1	11,6
	100	100	100	100	100	100	100	90,0	86,0	82,0	80,0	64,0	56,0	48,0	42,0	36,0	26,0	24,0	18,4
	160	160	160	160	160	160	160	144	138	131	128	102	89,6	76,8	67,2	57,6	41,6	38,4	29,4
	250	250	250	250	250	250	250	225	215	205	200	160	140	120	105	90,0	65,0	60,0	46,0
	320	320	320	320	320	320	320	288	275	262	256	205	179	154	134	115	83,2	76,8	58,9
	400	400	400	400	400	400	400	360	344	328	320	256	224	192	168	144	104	96,0	73,6
	500	500	500	500	500	500	500	450	430	410	400	320	280	240	210	180	130	120	92

Material	PN	Admissible operating pressure PS [bar] at operating temperature TS [°C]																	
		-10	200	250	300	350	400	450	475	490	500	510	520	530	540	550	575	580	600
X6CrNiMoTi 17-12-2 (1.4571) ¹⁾	63	63	61,7	57,9	54,9	53,3	51,4	50,1	50,1	49,9	49,9	49,9	49,6	49,6	49,4	49,1	48,6	40,3	35,3
	100	100	98,0	92,5	87,2	84,2	81,6	79,6	79,6	79,2	79,2	79,2	78,8	78,8	78,4	78,0	77,2	64,0	56,0
	160	160	157	148	140	135	131	127	127	127	127	127	126	126	125	125	124	102	89,6
	250	250	245	231	218	211	204	199	199	198	198	198	197	197	196	195	193	160	140
	320	320	314	293	279	270	261	255	255	253	253	253	252	248	236	228	193	160	140
	400	400	392	370	349	337	326	318	318	317	317	317	315	310	295	285	193	160	140

Material	PN	Admissible operating pressure PS [bar] at operating temperature TS [°C]						
		-196	20	100	200	300	350	400
X6CrNiMoTi 17-12-2 (1.4571) ²⁾	63	63,0	63,0	60,5	51,7	42,8	40,3	37,8
	100	100	100	96,0	82,0	68,0	64,0	60,0
	160	160	160	154	131	109	102	96,0
	250	250	250	240	205	170	160	150

Material	PN	Admissible operating pressure PS [bar] at operating temperature TS [°C]																			
		-10	200	250	300	350	400	450	480	490	500	510	520	530	540	550	560	570	580	590	600
X10CrMoVNb9-1 (F91) (1.4903) ³⁾	63	69,3	69,3	69,3	69,3	69,3	69,3	63,0	63,0	63,0	63,0	61,7	60,5	59,2	58,0	52,9	50,8	49,1	40,1	37,3	35,4
	100	110	110	110	110	110	110	100	100	100	100	98,0	96,0	94,0	92,0	84,0	80,6	78,0	63,6	59,2	56,2
	160	176	176	176	176	176	176	160	160	160	160	157	154	150	147	134	129	125	102	94,7	89,9
	250	275	275	275	275	275	275	250	250	250	250	245	240	235	230	210	202	195	159	148	141
	320	352	352	352	352	352	352	320	320	320	320	314	307	301	294	269	258	250	204	189	180
	400	440	440	440	440	440	440	400	400	400	400	392	384	376	368	336	322	312	254	236	224
	500	550	550	550	550	550	550	500	500	500	500	490	480	470	460	420	403	390	318	296	281

1) Use of valve above 400°C only for media without risk of intercrystalline corrosion

2) Application for temperatures from - 196 °C to + 400 °C, material variant 2 - see below

3) Application for temperatures up to + 650 °C - on request

Special materials on request: 1.7715, 15128

USED MATERIALS

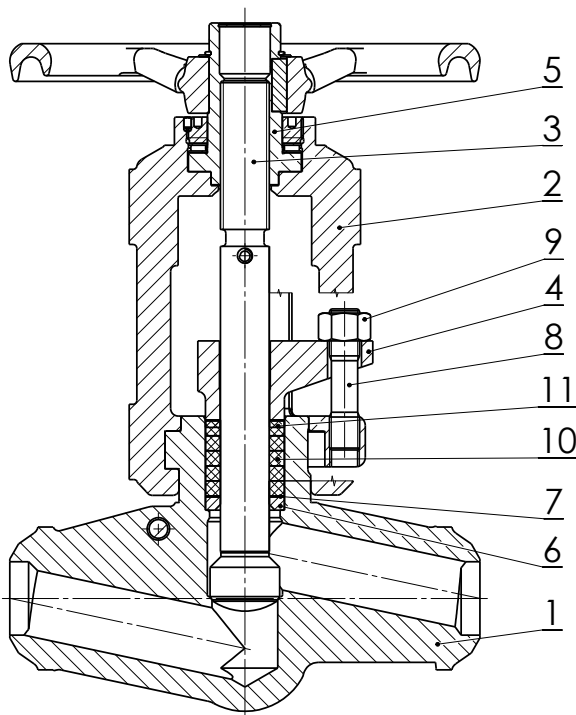

Pos.	Part	Material							
1	Body	P250GH (C22.8) (1.0460) 11416	16Mo3 (1.5415)	13CrMo4-5 (1.7335)	11CrMo9-10 (1.7383)	14MoV6-3 (1.7715) 15128	X10Cr- MoVNb9-1, (F91), (1.4903)	X6CrNiMo- Ti17-12-2 (1.4571) 1) (A182-F316Ti)	X6CrNiMoTi 17-12-2 (1.4571) 2) (A182-F316Ti)
	Hard facing of sealing surface	13Cr 3)	Stellite 6						
2	Yoke	G17CrMo9-10 (1.7379)							GX5CrNiMo 19-11-2 (1.4408)
3	Stem	X20Cr13 (1.4021)	X22CrMoV12-1 (1.4923)						X6CrNiMo- Ti17-12-2 (1.4571)
	Hard facing of sealing surface	Hardened 3)	Stellite 6						
4	Gland	11CrMo9-10 (1.7383, 1.7380, 1.0425, 1.0460, 1.7379)	11CrMo9-10 (1.7383, 1.7380, 1.7379)						GX5CrNiMo 19-11-2 (1.4408)
5	Stem nut	C45 (1.0503)							CuAl10Fe3Mn2 (2.0936)
6	Ring	A439 D2 NiResist , GX70CrMo29-2 (1.4136)							
7	Scraper ring	CrNi-steel graphite							
8	Bolt	21CrMoV5-7 (1.7709)							A2-70
9	Nut	25CrMo4 (1.7218)							A2
10	Gasket	Graphite pressed							
11	Gasket	Graphite knitted							

1) Use of valve above 400 °C only for media without risk of intercrystalline corrosion

2) Application for temperatures from - 196 °C to + 400 °C, material variant 2

3) Option on request - Stellite 6

VALVE DIMENSIONS

1. Flanged

Face-to-face dimensions: as per table
 Flanges: EN 1092-1, (DIN 250/1972), sealing bar – Form B1
 Other variants at the customer's request.

2. Weld ends, socket weld

Face-to-face dimensions: as per table
 Dimensions of welding ends: EN 12627
 (on request according to invalid standard DIN 3239-1)
 Groove form: ISO 9692-1
 (on request according to invalid standard DIN 2559-1)
 Socket weld: B16.11, DIN 3239 – part 2

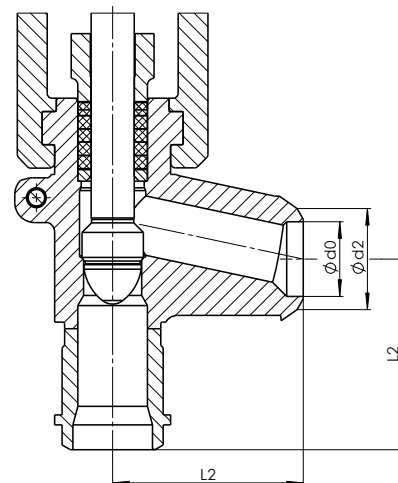
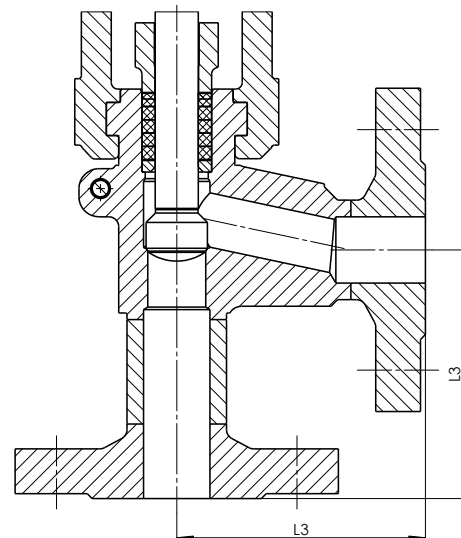
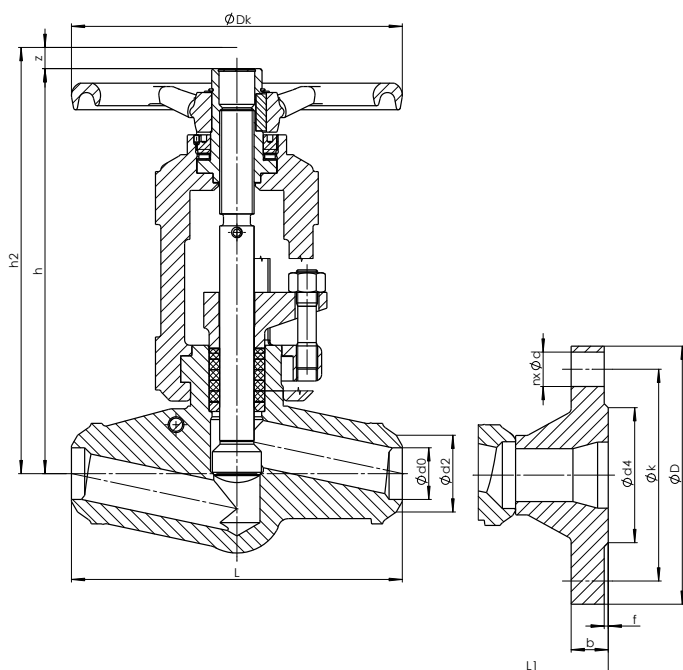

WELDING ENDS

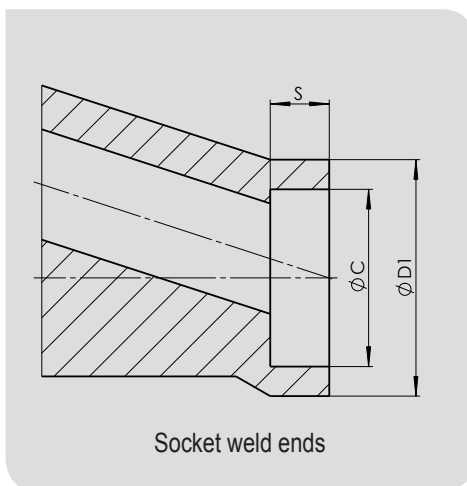
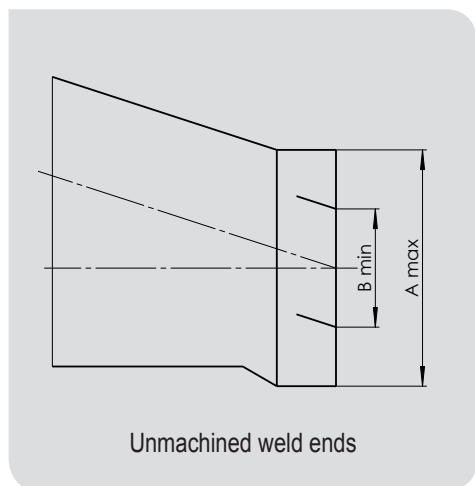

WELDING DESIGN

Nominal pressure	Nominal size	Face-to-face	Face-to-face (Angle valve)	Centre-to-top	Disassembly height	Stroke	Centre-to-top (E-actuator)	E-actuator connection EN ISO 5210	Handwheel	Weld ends ¹⁾		Socket weld acc. to B16.11 or DIN 3239-2			Unmachined weld ends		Approximate weight	Pipe dimension
										d_2	d_0	$\varnothing D_{1-0,5}$	$\varnothing C^{+0,2}$	b_{min}	A_{max}	B_{min}		
PN	DN	L	L2	h	h_2	z	h_3		$\varnothing D_k$									
63 100	10	150	105	225	330	11	288	F10 B1	200	18	13,2	33	18	9,5	35	9	6,5	17,2x2,0
	15	150	105	225	330	11	288	F10 B1	200	22	17,3	33	22	9,5	35	14	6,4	21,3x2,0
	20	160	110	240	360	18	288	F10 B1	250	28	22,3	48	27,5	12,7	50	19	9,0	26,9x2,3
	25	160	110	240	360	18	288	F10 B1	250	35	28,5	48	34,5	12,7	50	24	8,5	33,7x2,6
	32	250	-	320	430	28	290	F10 B1	250	44	37,2	76	43	12,7	75	29	18,2	42,4x2,6
	40	250	-	320	430	28	290	F10 B1	250	50	43,1	76	49	12,7	75	35	18,6	48,3x2,6
	50	250	-	320	430	28	290	F10 B1	250	62	53,9	76	61	15,9	75	35	18,6	60,3x3,2
65	340	-	454	600	40	-	-	-	500	78	68,9	90	74	16	100	48	58	76,1x3,6
160	10	150	105	225	330	11	288	F10 B1	200	18	13,2	33	18	9,5	35	9	6,5	17,2x2,0
	15	150	105	225	330	11	288	F10 B1	200	22	17,3	33	22	9,5	35	14	6,4	21,3x2,0
	20	160	110	240	360	18	288	F10 B1	250	28	22,3	48	27,5	12,7	50	19	9,0	26,9x2,3
	25	160	110	240	360	18	288	F10 B1	250	35	27,3	48	34,5	12,7	50	24	8,5	33,7x3,2
	32	250	-	320	430	28	290	F14 B1	250	44	35,2	76	43	12,7	75	29	18,2	42,4x3,6
	40	250	-	320	430	28	290	F14 B1	250	50	41,1	76	49	12,7	75	35	18,6	48,3x3,6
	50	250	-	320	430	28	290	F14 B1	250	62	52,3	76	61	15,9	75	35	18,6	60,3x4,0
65	340	-	454	600	40	-	-	-	500	78	64,9	90	74	16	100	48	58	76,1x5,6
250	10	150	105	225	330	11	288	F10 B1	200	18	12,0	33	18	9,5	35	9	6,5	17,2x2,6
	15	150	105	225	330	11	288	F10 B1	200	22	16,1	33	22	9,5	35	14	6,4	21,3x2,6
	20	160	110	240	360	18	288	F10 B1	250	28	19,7	48	27,5	12,7	50	19	9,0	26,9x3,6
	25	160	110	240	360	18	288	F10 B1	250	35	26,5	48	34,5	12,7	50	24	8,5	33,7x3,6
	32	250	-	320	430	28	316	F14 B1	355	44	33,4	76	43	12,7	75	29	18,2	42,4x4,5
	40	250	-	320	430	28	316	F14 B1	355	50	38,3	76	49	12,7	75	35	18,6	48,3x5,0
	50	250	-	320	430	28	316	F14 B1	355	62	44,3	76	61	15,9	75	35	18,6	60,3x8,0
65	340	-	454	600	40	-	-	-	500	78	58,5	90	74	16	100	48	58	76,1x8,8
320	10	150	105	225	330	11	288	F10 B1	200	18	12,0	33	18	9,5	35	9	6,5	17,2x2,6
	15	150	105	225	330	11	288	F10 B1	200	22	14,9	33	22	9,5	35	14	6,4	21,3x3,2
	20	160	110	240	360	18	290	F10 B1	250	28	18,9	48	27,5	12,7	50	19	9,0	26,9x4,0
	25	160	110	240	360	18	290	F10 B1	250	35	23,7	48	34,5	12,7	50	24	8,5	33,7x5,0
	32	250	-	320	430	28	316	F14 B1	355	44	29,8	76	43	12,7	75	29	18,2	42,4x6,3
	40	250	-	320	430	28	316	F14 B1	355	50	35,7	76	49	12,7	75	35	18,6	48,3x6,3
	50	250	-	320	430	28	316	F14 B1	355	62	44,3	76	61	15,9	75	35	18,6	60,3x8,0
65	340	-	454	600	40	340	F16 B1	630	78	56,1	90	74	16	100	48	60	76,1x10	
400	10	150	105	225	330	11	288	F10 B1	250	18	10,0	-	-	-	35	9	7,2	17,2x3,6
	15	150	105	225	330	11	288	F10 B1	250	22	14,9	-	-	-	35	14	7,1	21,3x3,2
	20	160	110	240	360	18	290	F10 B1	250	28	18,9	-	-	-	48	18	9,1	26,9x4,0
	25	160	110	240	360	18	290	F10 B1	250	35	23,7	-	-	-	48	22	9,0	33,7x5,0
	32	250	-	320	430	28	316	F14 B1	355	44	29,8	-	-	-	78	30	19,8	42,4x6,3
	40	250	-	320	430	28	316	F14 B1	355	50	32,3	-	-	-	78	32	19,0	48,3x8,0
	50	250	-	320	430	28	316	F14 B1	355	62	42,7	-	-	-	78	38	19,0	60,3x8,8
65	340	-	454	600	40	340	F16 B1	-	78	51,1	-	-	-	100	48	-	76,1x12,5	

PN	DN	L	L2	h	h ₂	z	h ₃		∅D _k	d ₂	d ₀	∅D _{1-0,5}	∅C ^{+0,2}	b _{min}	A _{max}	B _{min}	m [kg]	
500	10	150	105	225	330	11	290	F10 B1	250	18	10,0	-	-	-	35	9	7,2	17,2x3,6
	15	150	105	225	330	11	290	F10 B1	250	22	13,3	-	-	-	35	14	7,1	21,3x4,0
	20	160	110	240	360	18	290	F10 B1	250	28	16,9	-	-	-	48	18	9,1	26,9x5,0
	25	160	110	240	360	18	290	F10 B1	250	35	21,1	-	-	-	48	22	9,0	33,7x6,3
	32	250	-	320	430	28	316	F14 B1	355	44	26,4	-	-	-	78	30	19,8	42,4x8,0
	40	250	-	320	430	28	316	F14 B1	355	50	30,7	-	-	-	78	32	19,0	48,3x8,8
	50	250	-	320	430	28	316	F14 B1	355	62	38,3	-	-	-	78	38	19,0	60,3x11
	65	340	-	454	600	40	-	-	-	78	47,7	-	-	-	100	48	-	76,1x14,2

Missing data in the chart on request.

1) Dimensions d0 is based on the internal diameter of the pipes

FLANGE DESIGN

Nominal pressure	Nominal size	Face-to face	Face-to face Angle Valve	Number of holes	Hole	Pitch circle	Flange diameter	Flange thickness	Smooth bar	Approximate weight
PN	DN	L1	L3	n	∅d	∅k	∅D	b	∅d _{4xf}	m [kg]
63, 100	10	230	105	4	14	70	100	20	40x2	10,0
	15	230	105	4	14	75	105	20	45x2	10,9
	20	260	115	4	18	90	130	22	58x2	14,0
	25	260	115	4	18	100	140	24	68x2	14,5
	32	390	150	4	22	110	155	24	78x2	27,0
	40	390	150	4	22	125	170	26	88x3	29,0
63	50	390	150	4	22	135	180	26	102x3	31,0
100	50	390	150	4	26	145	195	28	102x3	31,0
63	65	540	-	8	22	160	205	26	122x3	-
100	65	540	-	8	26	170	220	30	122x3	-
160	10	230	105	4	14	70	100	20	40x2	10,0
	15	230	105	4	14	75	105	20	45x2	10,9
	25	260	115	4	18	100	140	24	68x2	14,5
	40	390	150	4	22	125	170	28	88x3	29,0
	50	390	150	4	26	145	195	30	102x3	31,0
	65	540	-	8	26	170	220	34	122x3	-
250	10	230	115	4	18	85	125	24	40x2	10,0
	15	230	115	4	18	90	130	26	45x2	10,9
	25	260	130	4	22	105	150	28	68x2	14,5
	40	390	-	4	26	135	185	34	88x3	29,0
	50	390	-	8	26	150	200	38	102x3	31,0
	65	540	-	8	26	180	230	42	122x3	-
320	10	230	115	4	18	85	125	24	40x2	10,0
	15	230	115	4	18	90	130	26	45x2	10,9
	25	260	130	4	22	115	160	34	68x2	17,5
	40	390	150	4	26	145	195	38	88x3	32,0
	50	390	175	8	26	160	210	42	102x3	36,0
	65	540	-	8	30	200	255	51	122x3	-
400	10	230	115	4	18	85	125	28	40x2	10,0
	15	230	115	4	22	100	145	30	45x2	10,9
	25	260	130	4	26	130	180	38	68x2	17,5
	40	390	-	4	30	165	220	48	88x3	32,0
	50	390	-	8	30	180	235	52	102x3	36,0
	65	540	-	8	33	225	290	64	122x3	-

Missing data in the chart on request.

DESIGN VARIANTS

ATTACHMENT FOR ACTUATOR

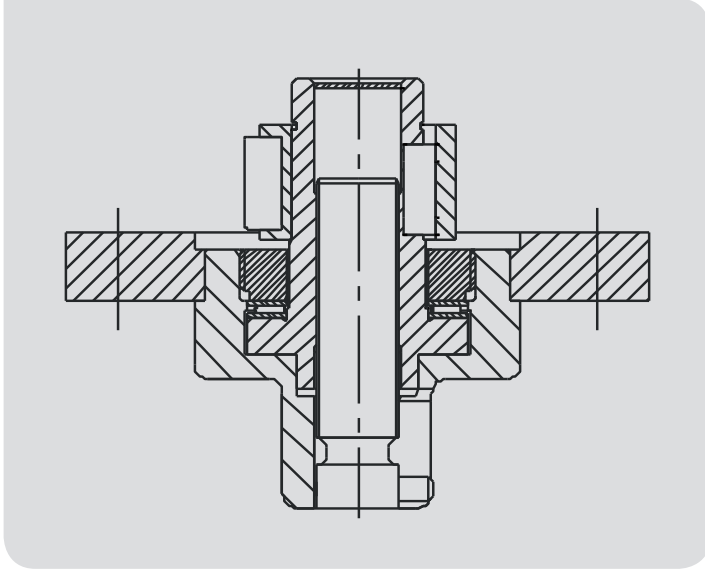

GASKET WITH SCRAPER RING

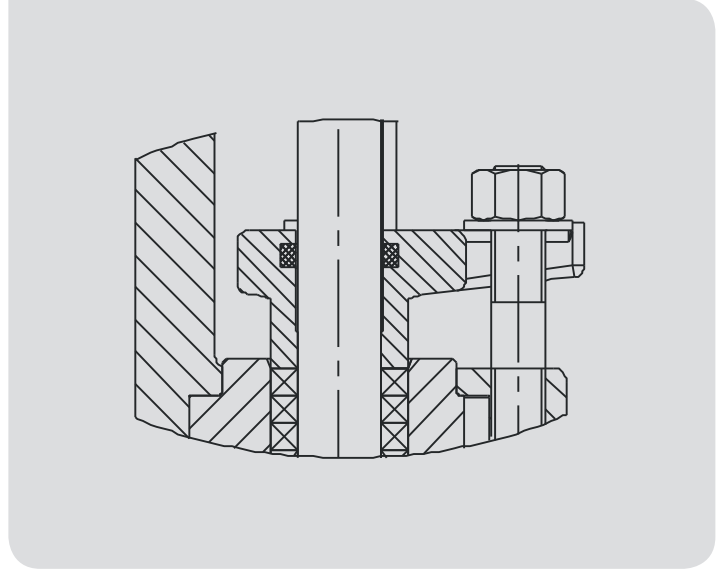

LOCKING DEVICE

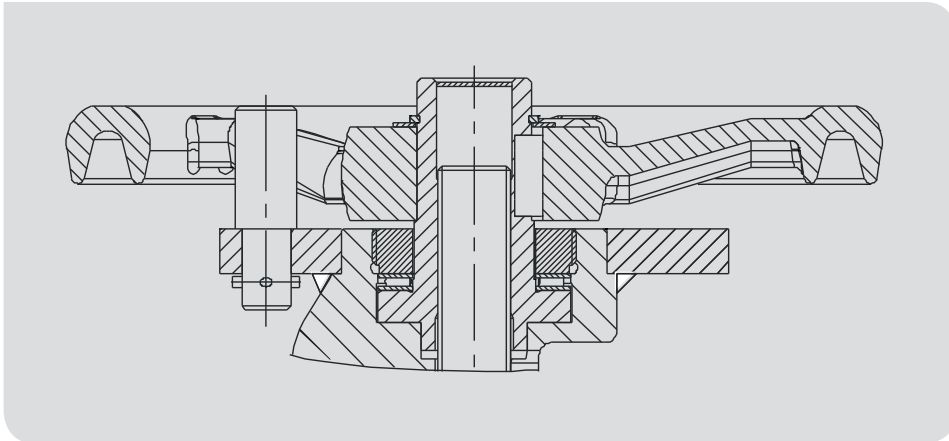

BASIC FEATURES

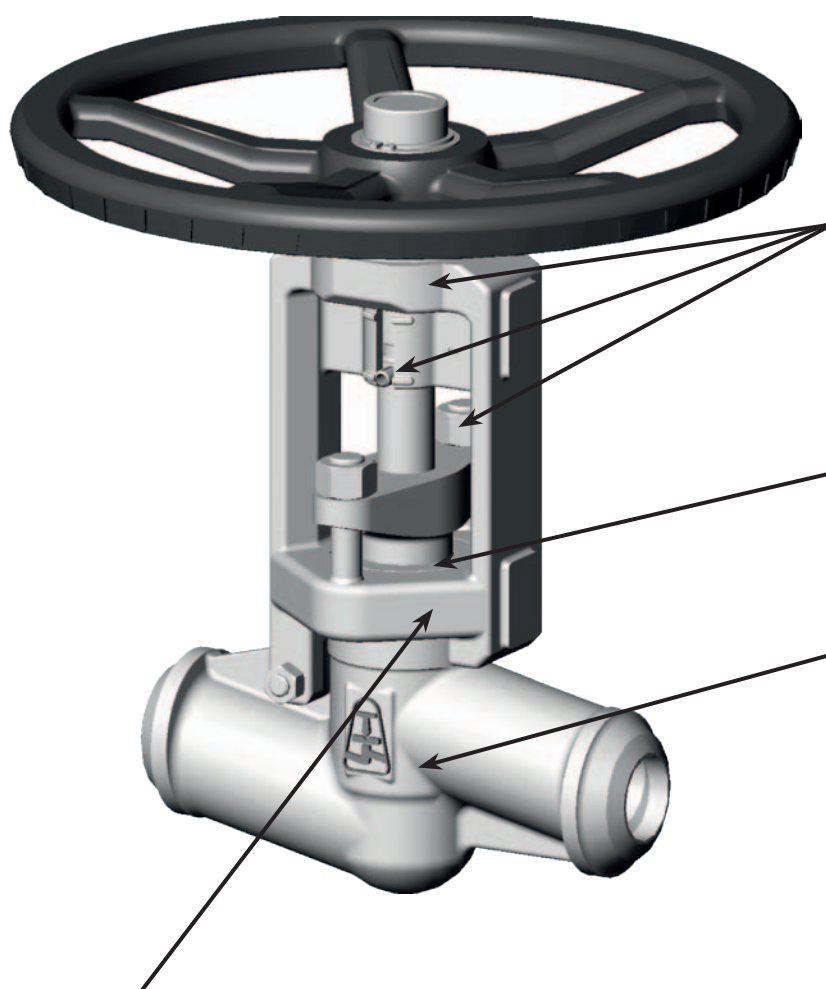

High reliable valve

- Only one sealed place
- To prevent vibrations, the disc is part of the stem

Easy use

- Position indicator as standard
- Wider distance between the yoke-arms for easy maintenance
- Bearings for easy operation

Long service life of the packing

- Stem with low roughness
- Non-rotating stem

Long service life of the seats

- Seats are hard faced with corrosion proof 13Cr steel or Stellite 6

Reduced construction height

Reduced operational costs

- Lower pipeline weighting by reason of low weight

Reduced service costs

- Bayonet connection of body and yoke makes possible fast yoke dismantling
- Lowered seat depth makes easier and speeds up service action
- Easy seat repair – lowered seat depth compared to similar globe valves
- Due to absent of cover connection the control and tightening necessity of cover connection screws is cancelled

VALVE DESCRIPTION CODE

V46.2 111–3250–25

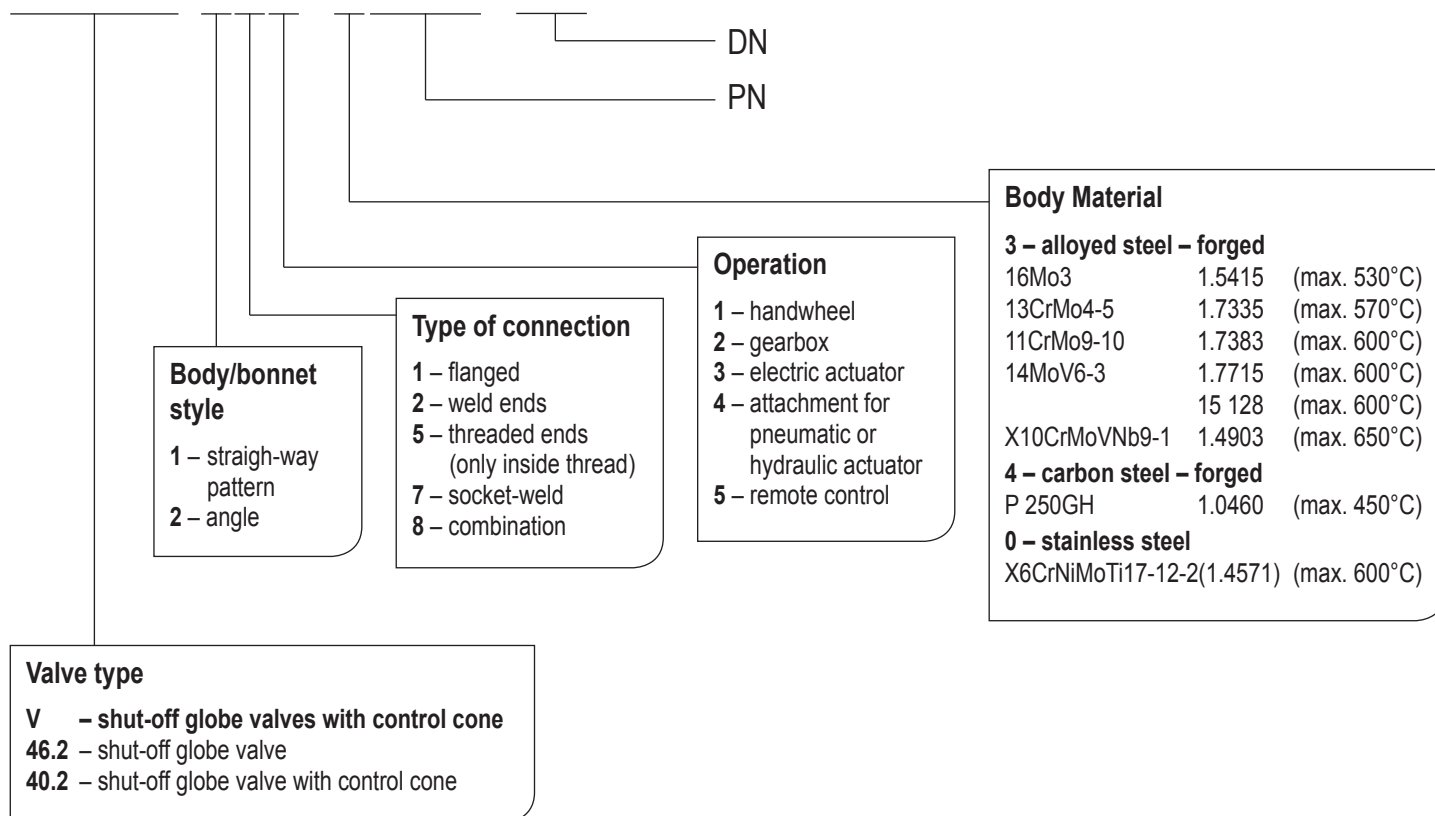

VALVE INSTALLATION

Valve can be installed in any position. Medium must flow under the cone in accordance with the direction indicated on the valve body. It is necessary to consider the following points during assembly and operation:

- operating conditions must comply with operating parameters of the valve
- proper function of the valve is affected by the presence of impurities in the pipeline and flowing medium, therefore it is necessary to keep working environment a pipeline clean, for example with using filters
- the medium used must comply with the corrosion resistance of the valve material
- use of mechanically damaged valves during the operation is prohibited

The service life of a valve can be significantly extended by regular maintenance and repairs carried out by qualified personnel.