

ENERGY REDUCER M25

PN 160, 250 DN 40, 50, 65, 100, 125; PN 400 DN 100, 125, 150: T_{MAX}: 450 °C

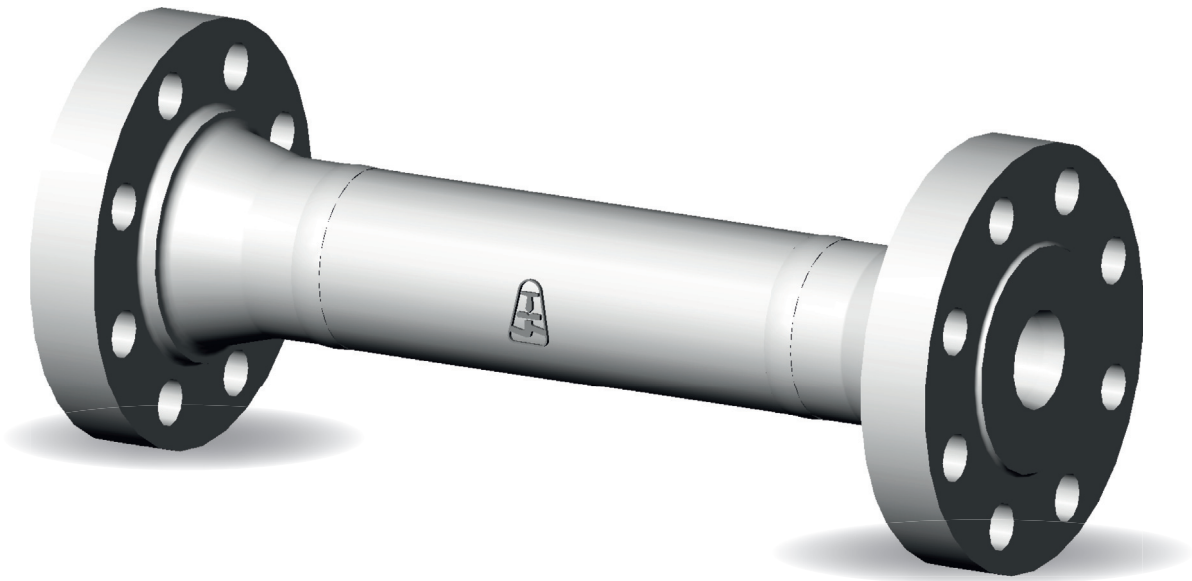

ENERGY REDUCER M25

APPLICATION

- water, non-aggressive substances

CONNECTION

- weld ends, flanged

OPERATION

- without operation

DESCRIPTION

- orifice plate – REAL 096
- complies with the requirements of the directive 2014/68/EU
- testing is carried out according to EN 12266-1

BASIC DESIGN OPTION

- other tests on request
- delivery according to TRD 201 on request

PRESSURE-TEMPERATURE-RATINGS

Material	PN	Admissible operating pressure PS [bar] at operating temperature TS [°C]										
		-10	20	50	100	150	200	250	300	350	400	450
P250GH (C22.8) (1.0460) (12 020) ¹⁾	160	160	160	160	148	141	133	122	110	103	95	53
	250	250	250	250	232	220	208	190	173	161	149	82
	400	400	400	400	371	352	333	305	276	257	238	131

1) Application up to 350 °C

USED MATERIALS

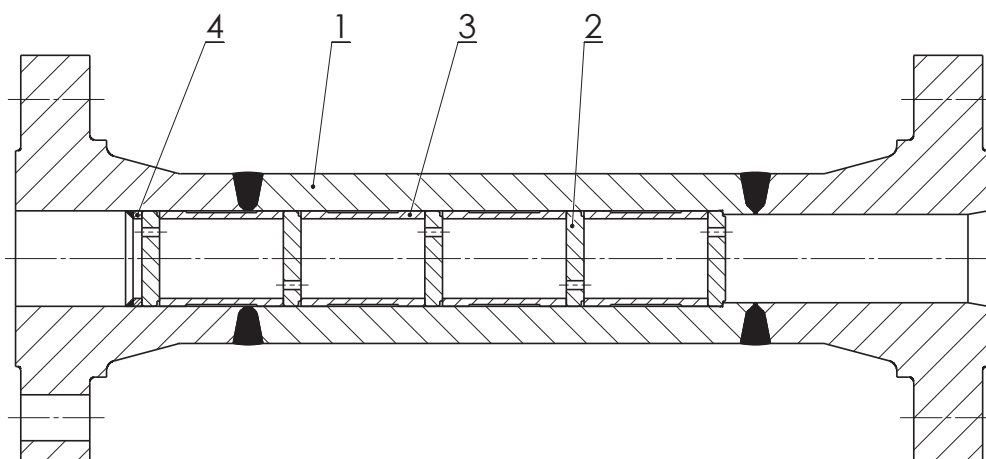

Pos.	Part	Material
1	Body	P250GH (C22.8) (1.0460)
2	Orifice plate	REAL 096
3	Spacer	X6CrNiTi18-10 (1.4541)
4	Ring	X6CrNiTi18-10 (1.4541)

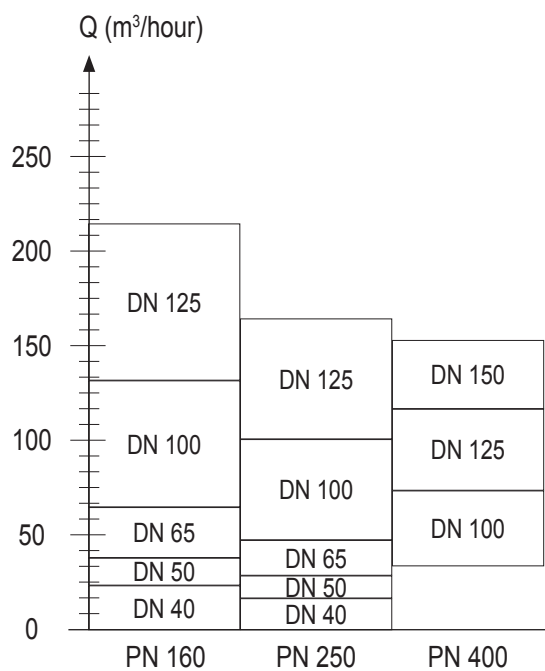

VALVE DIMENSIONS

1. Weld ends

Face-to-face dimensions: as per table
 Weld ends: ČSN 13 1075
 Groove form: DIN 2559 – sheet 1 – form 22

2. Flanged

Face-to-face dimensions: as per table
 Flanged: EN 1092-1, (DIN 2501/1972)

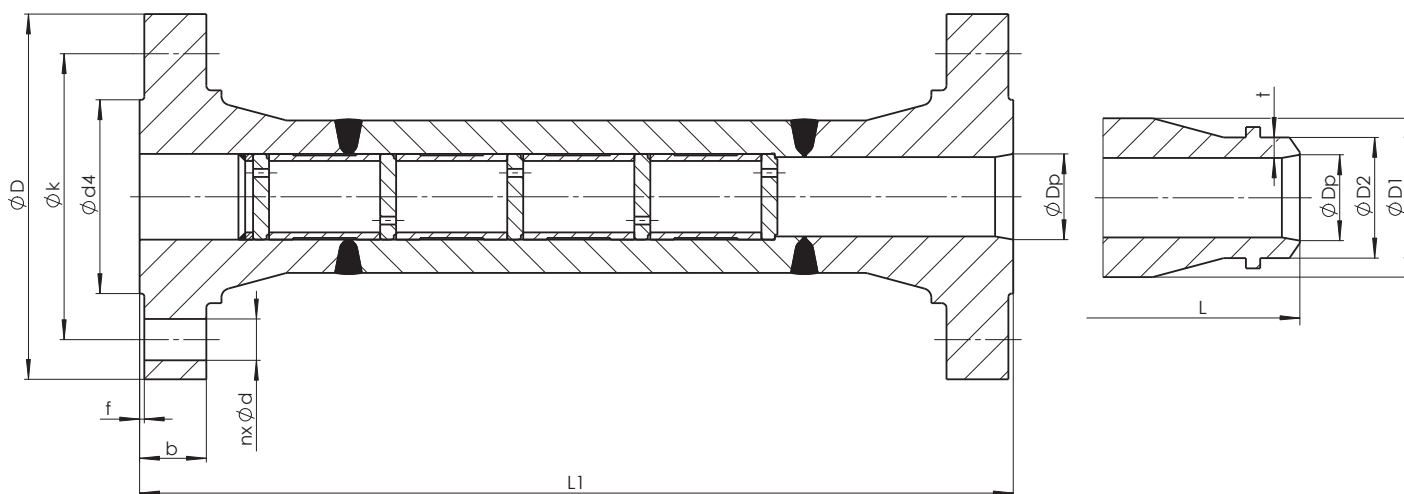

Nominal pressure	Nominal size	Face-to-face	Connective dimensions				Weight approximately
			$\varnothing D_1$	$\varnothing D_2$	$\varnothing D_p$	t	
PN	DN	L	$\varnothing D_1$	$\varnothing D_2$	$\varnothing D_p$	t	m [kg]
160	40	360	65	44,5	35,3	4,5	15
	50	450	80	57	46	5,5	19,8
	65	550	100	76	62	7	27,7
	100	600	140	109	88	10	48,2
	125	650	160	134	109	11,5	64,1
250	40	360	65	44,5	32	7	21
	50	450	80	57	44	8	*)
	65	550	100	76	54	12	42
	100	600	140	109	80	14,5	79
	125	650	160	134	100	18,5	94,5
400	100	600	140	109	70	19,5	57,4
	125	650	160	134	*)	25	107,6
	150	700	190	160	100	32	126,8

*) Missing data on request

Nominal pressure	Nominal size	Face-to-face	Diameter on output	PN 160						
				Number of holes	Hole diameter	Pitch circle	Flanges diameter	Flange thickness	Smooth bar	Weight approximately
PN	DN	L1	$\varnothing D_p$	n	$\varnothing d$	$\varnothing k$	$\varnothing D$	b	$\varnothing d_4 \times f$	m [kg]
160	40	360	35,3	4	22	125	170	28	88x3	*)
	50	450	46	4	26	145	195	30	102x3	*)
	65	550	62	8	26	170	220	34	122x3	*)
	100	600	88	8	30	210	265	40	162x3	*)
	125	650	109	8	33	250	315	44	188x3	*)
250	40	360	32	4	26	135	185	34	88x3	*)
	50	450	44	8	26	150	200	38	102x3	*)
	65	550	54	8	26	180	230	42	122x3	*)
	100	600	80	8	33	235	300	54	162x3	89
	125	650	100	12	33	275	340	60	188x3	*)
400	100	600	70	8	39	295	370	80	162x3	*)
	125	*)	*)	12	39	340	415	92	188x3	*)
	150	750	100	12	42	390	475	105	218x3	*)

*) Missing data on request

VALVE DESCRIPTION CODE

M25 120-4160-50

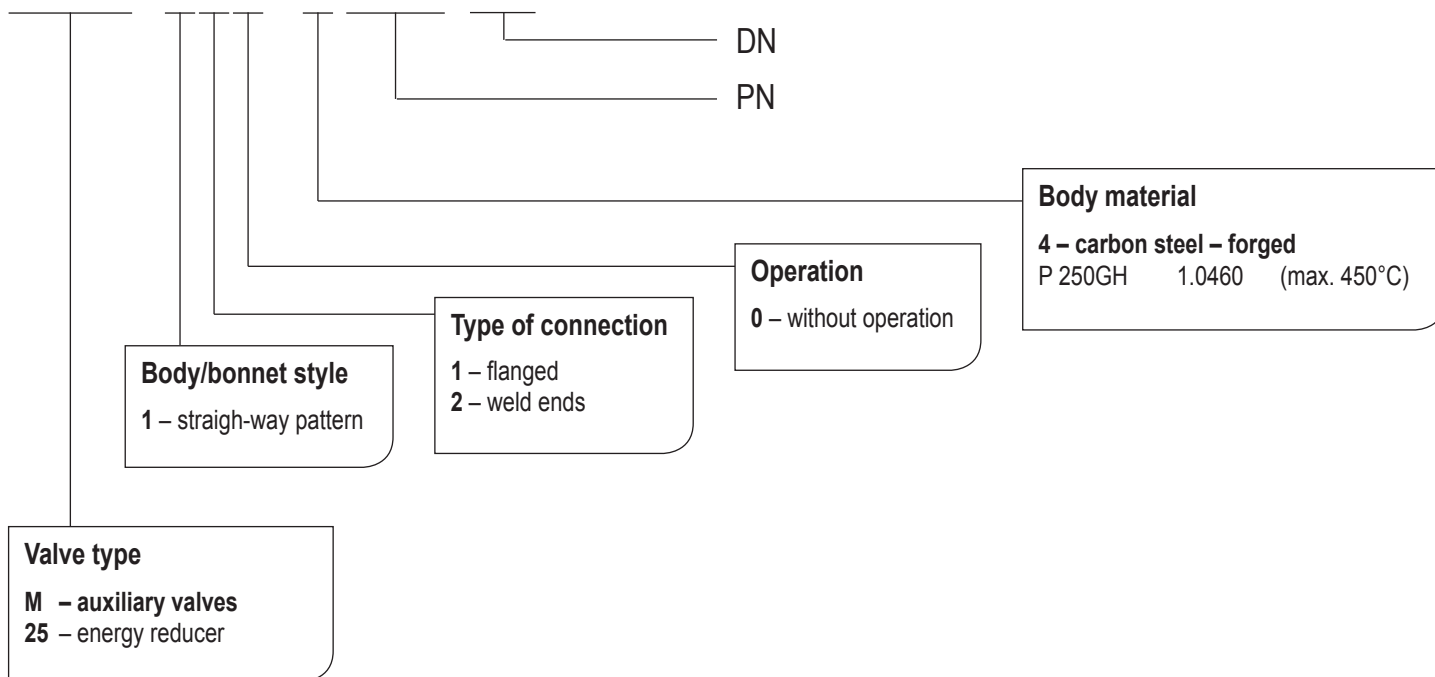

VALVE INSTALLATION

The energy reducer can be installed in any position with the direction of the working medium according to the arrow marked on the valve body. It is necessary to consider the following points during assembly and operation:

- operating conditions must comply with operating parameters of the valve
- proper function of the valve is affected by the presence of impurities in the pipeline and flowing medium, therefore it is necessary keep working environment a pipeline clean, for example with using filters
- medium used must comply with the corrosion resistance of the valve material
- use of mechanically damaged valves during the operation is prohibited

The service life of valves significantly extends regular maintenance and minor repairs carried out by trained personnel.