

LIFT CHECK VALVE Z35

PN 16-250; DN 65-150 (DN 80 AND DN 125 ONLY UP TO PN 100), T_{MAX}: 300°C

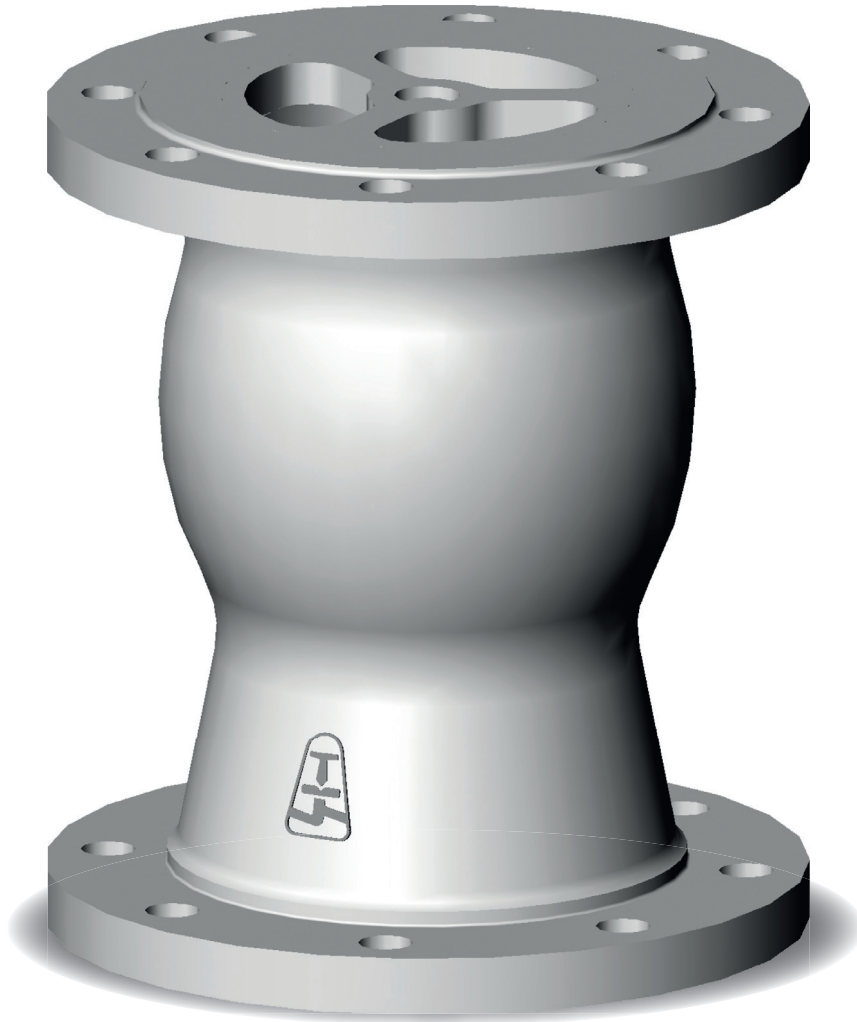

LIFT CHECK VALVE Z35

APPLICATION

- water, non-aggressive liquids

CONNECTION

- flanged

OPERATION

- self-acting control

DESCRIPTION

- check valve to vertical pipe
- straight – way pattern
- check valve disc
- sealing surfaces are welded by hard steel
- complies with the requirements of the directive 2014/68/EU
- testing is carried out according to EN 12266-1

BASIC DESIGN OPTIONS

- according to TRD 201

PRESSURE-TEMPERATURE-RATINGS

Material	PN	Admissible operating pressure PS [bar] at operating temperature TS [°C]						
		-10	50	100	150	200	250	300
GP240GH (1.0619)	16	16	16	14,9	13,9	12,4	11,4	10,3
	40	40	40	37,3	34,7	30,2	28,4	25,8
	63	63	63	58,8	54,6	47,6	44,8	40,6
	100	100	100	93,3	86,7	75,6	71,1	64,4
	160	160	160	160	157	128	110	94,1
	250	250	250	250	245	196	172	147

USED MATERIALS

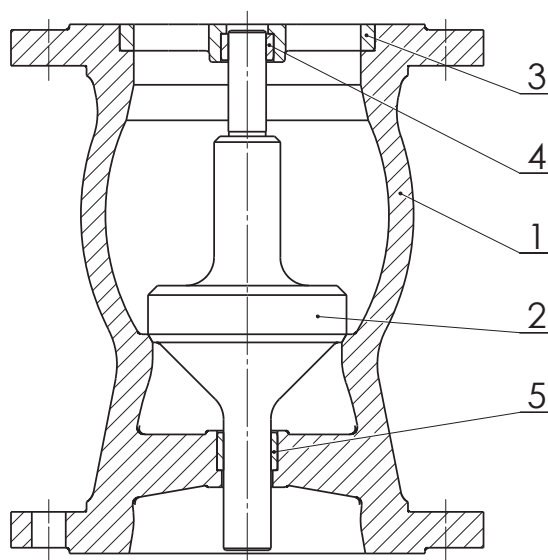

Pos.	Part	Material
1	Body	GP240GH (1.0619)
	Hard facing of sealing surface	13 Cr
2	Disc	X20Cr13 (1.4021)
3	Disc guide	11 523, 1.0425 (P265GH)
4, 5	Bushing	42 3018.21 (ČSN 02 3499)

VALVE DIMENSIONS

1. Flanged

Face-to-face dimensions: as per table

Flanges: EN 1092-1, (DIN 2501/1972)

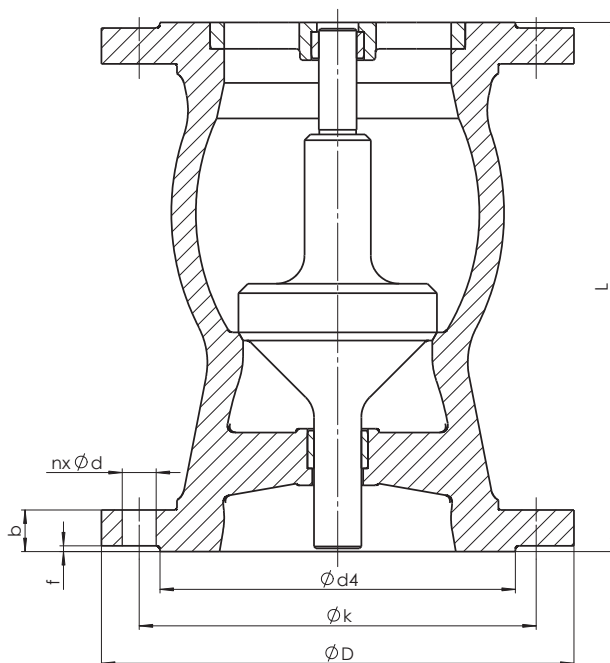

Nominal pressure	Nominal size	Face-to-face dimension	Flanged						
			PN	DN	L [mm]	n	d [mm]	k [mm]	D [mm]
16	65	180	8	18	145	185	18	122×3	12,0
	80	200	8	18	160	200	20	138×3	15,4
	100	230	8	18	180	220	20	158×3	18,5
	125	280	8	18	210	250	22	188×3	28,0
	150	330	8	22	240	285	22	212×3	43,0
40	65	180	8	18	145	185	22	122×3	12,8
	80	200	8	18	160	200	24	138×3	16,9
	100	230	8	22	190	235	24	162×3	21,0
	125	280	8	26	220	270	26	188×3	31,0
	150	330	8	26	250	300	28	218×3	47,0
63	65	180	8	22	160	205	26	122×3	16,3
	80	200	8	22	170	215	28	138×3	20,0
	100	230	8	26	200	250	30	162×3	27,1
	125	280	8	30	240	295	34	188×3	44,0
	150	330	8	33	280	345	36	218×3	66,0
100	65	180	8	26	170	220	30	122×3	19,6
	80	200	8	26	180	230	32	138×3	23,0
	100	230	8	30	210	265	36	162×3	32,0
	125	280	8	33	250	315	40	188×3	52,0
	150	330	12	33	290	355	44	218×3	76,0
160	65	200	8	26	170	220	34	122×3	25,0
	100	230	8	30	210	265	40	162×3	46,0
	150	300	12	33	290	355	50	218×3	104,0
250	65	200	8	26	180	230	42	122×3	30,0
	100	230	8	33	235	300	54	162×3	62,0
	150	300	12	36	320	390	68	218×3	133,0

VALVE DESCRIPTION CODE

Z35 117-5100-150

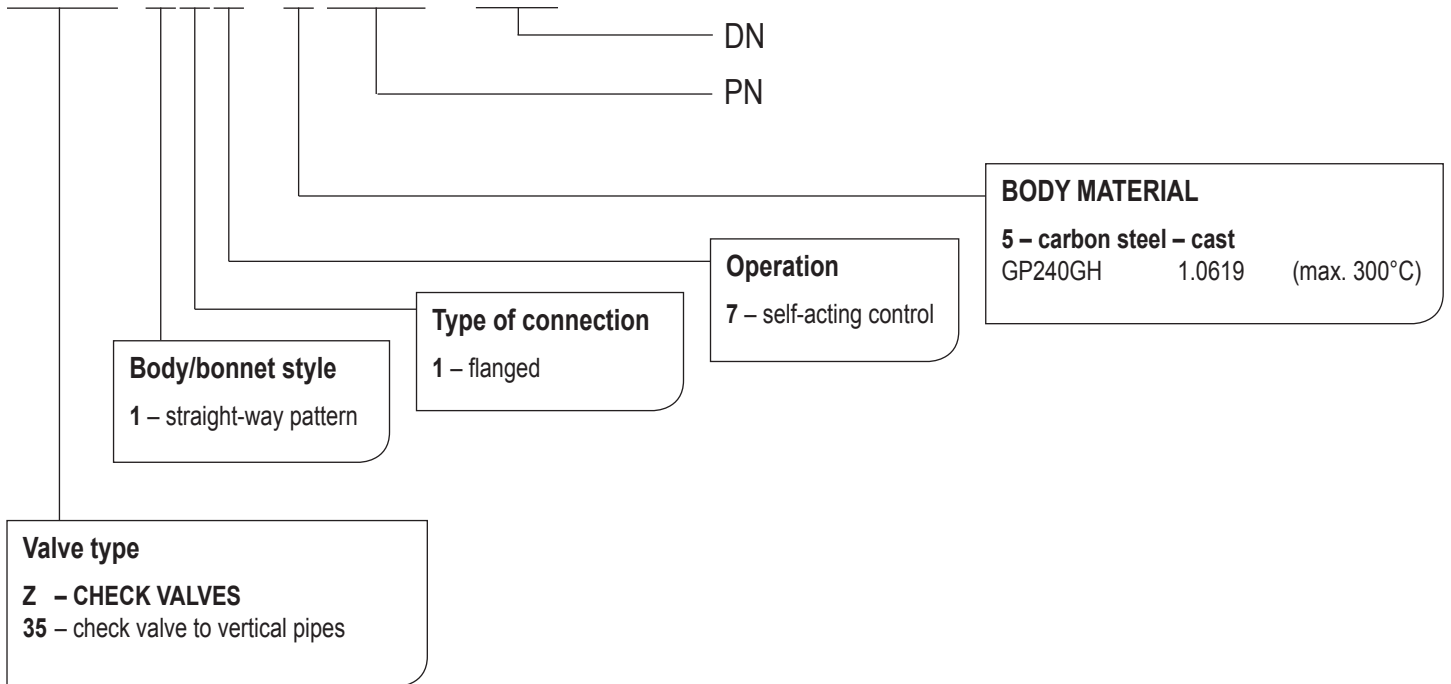

VALVE INSTALLATION

Lift check valve must be installed in the vertical position. Medium must flow under the cone in accordance with the direction indicated on the body. Installation and use the valve following points have to be respected:

- operating conditions must comply with operating parameters of the valve
- proper function of the valve is affected by the presence of impurities in the pipeline and flowing medium, therefore it is necessary keep working environment a pipeline clean, for example with using filters
- medium used must comply with the corrosion resistance of the valve material
- use of mechanically damaged valves during the operation is prohibited

The service life of valves significantly extends regular maintenance and minor repairs carried out by trained personnel.